

8	7	6	5	4	3	2	1
Spec.	mm	mm	kgf	r.p.m.	l	kg	Confirmed
Model	Plunger Stroke	Slider Stroke	Max D.B. pull	Max speed	kg · m ²	Weight	
FA-615	15	15	340	1200	-	11.9	

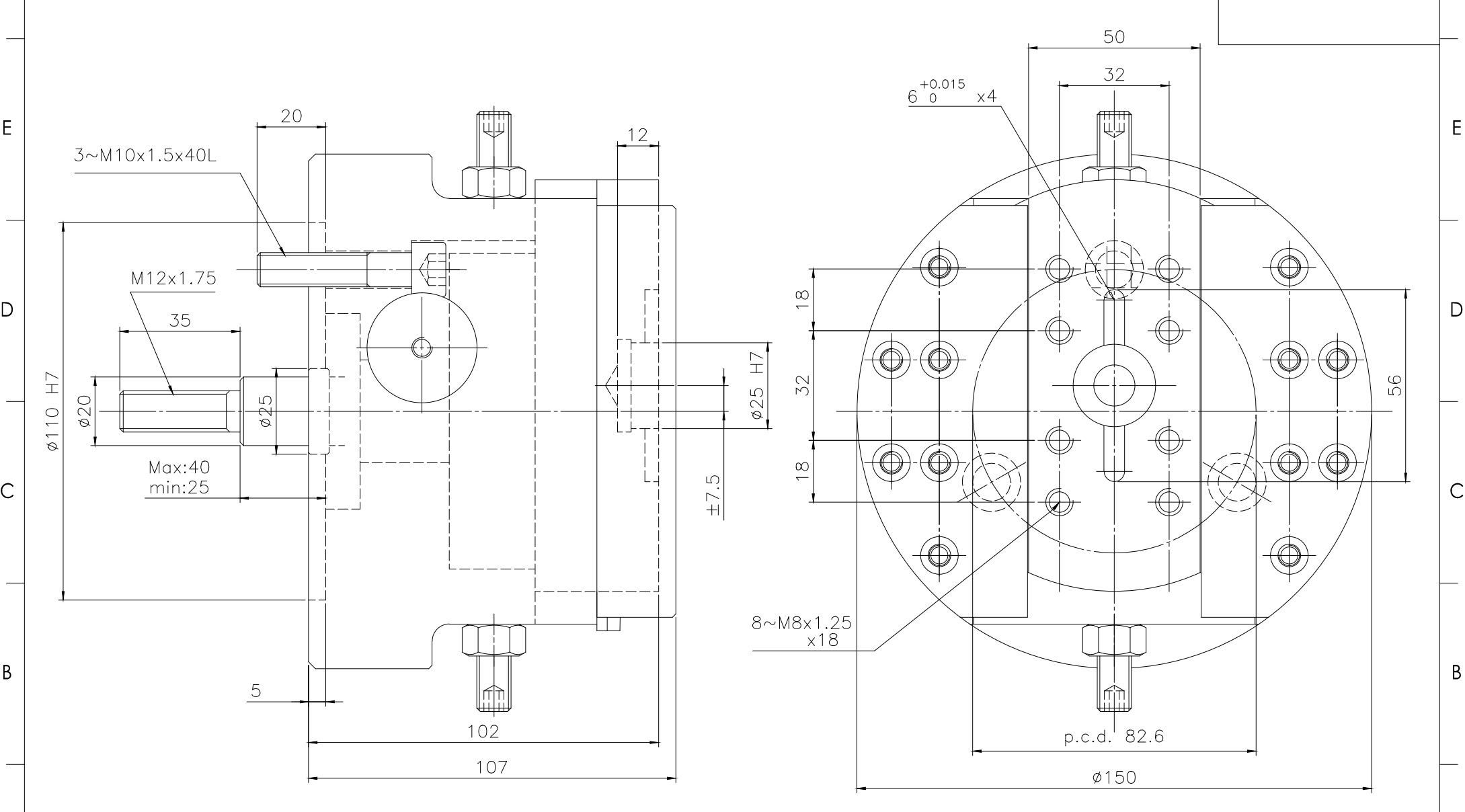

LEADER CHUCK INTERNATIONAL
+44 (0) 1827 700000
+353 (0)1 254 2555
INFORMATION@LEADERCHUCK.COM
LEADERCHUCK.COM

TITLE: Single Slide Facing Head
(Rack & Pinion Activation)

DRAWING NO.: A3\AG-FA-615

