

8	7		6	5		4	3	2	1
	Spec.	Eff. piston area cm ²		Chuck Dia. mm					
Model	Extend	Retract	Jaw Stroke (Dia.)	Max.	min.	Max clamping force	Max. pressure	Weight	Confirmed
VP-306	63.1	53.5	8.5	165	14	5350	34	19.3	

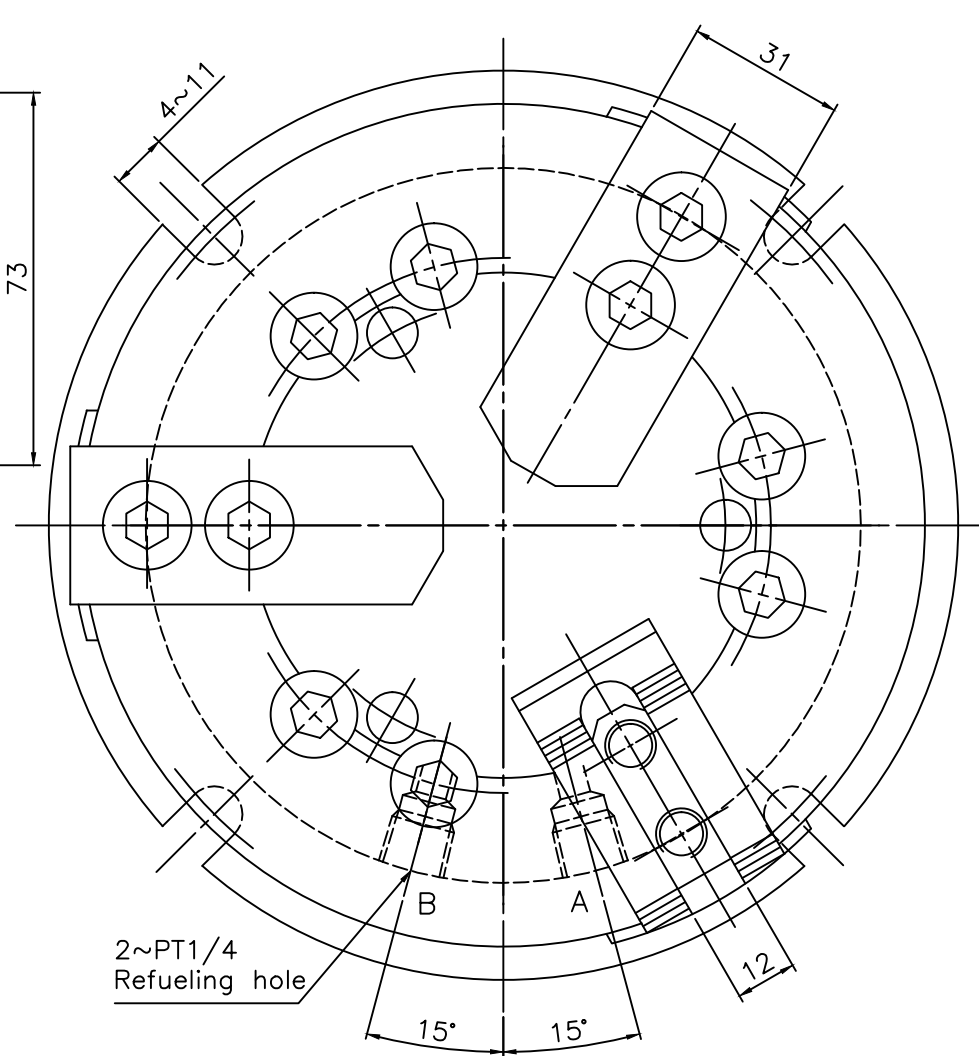
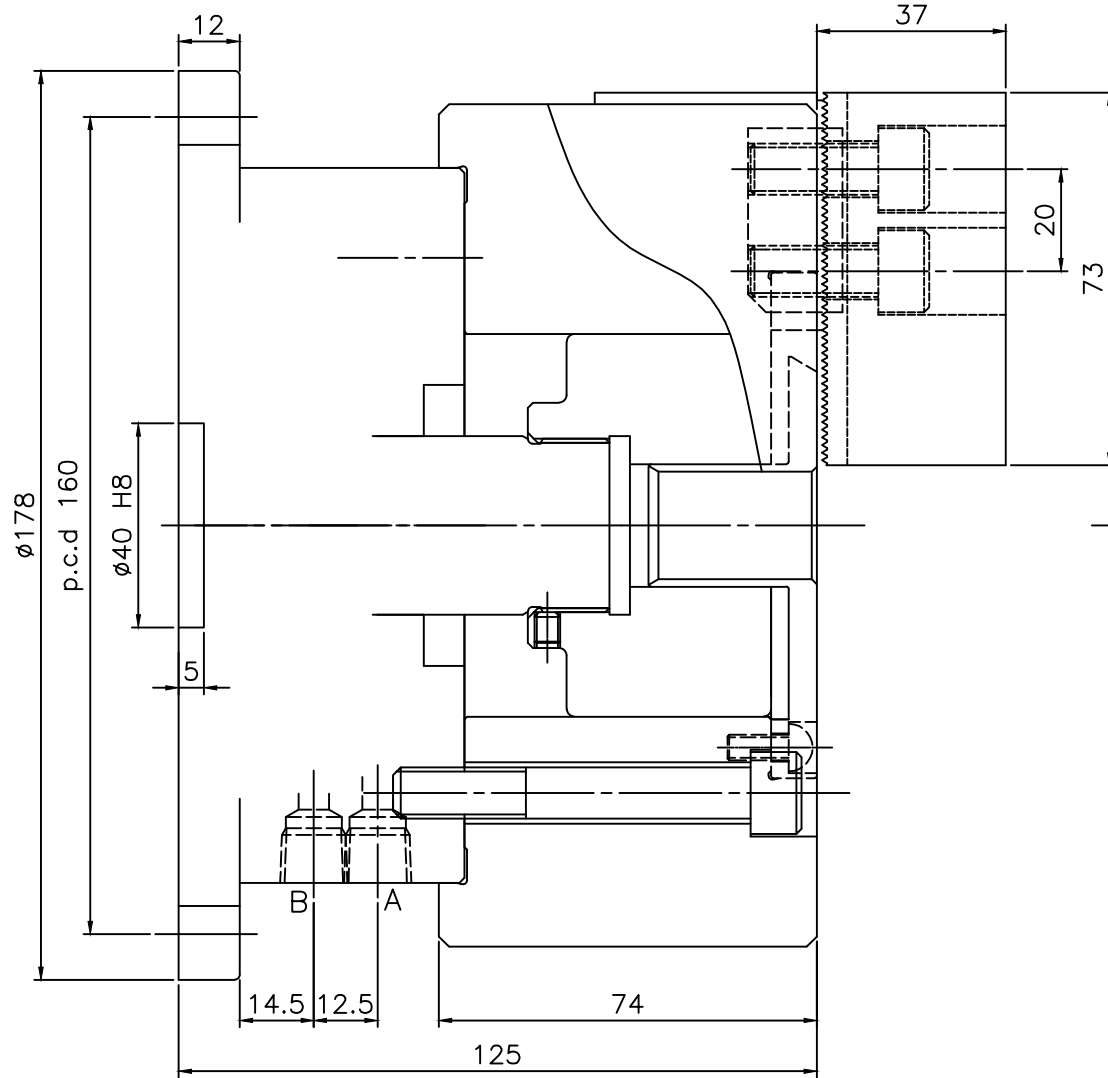

LEADER CHUCK INTERNATIONAL
+44 (0) 1827 700000
+353 (0)1 254 2555
INFORMATION@LEADERCHUCK.COM
LEADERCHUCK.COM

TITLE:
3 Jaw Closed Centre Self
Contained Power Chuck

DRAWING NO.:
A3\AG-VP-306

