

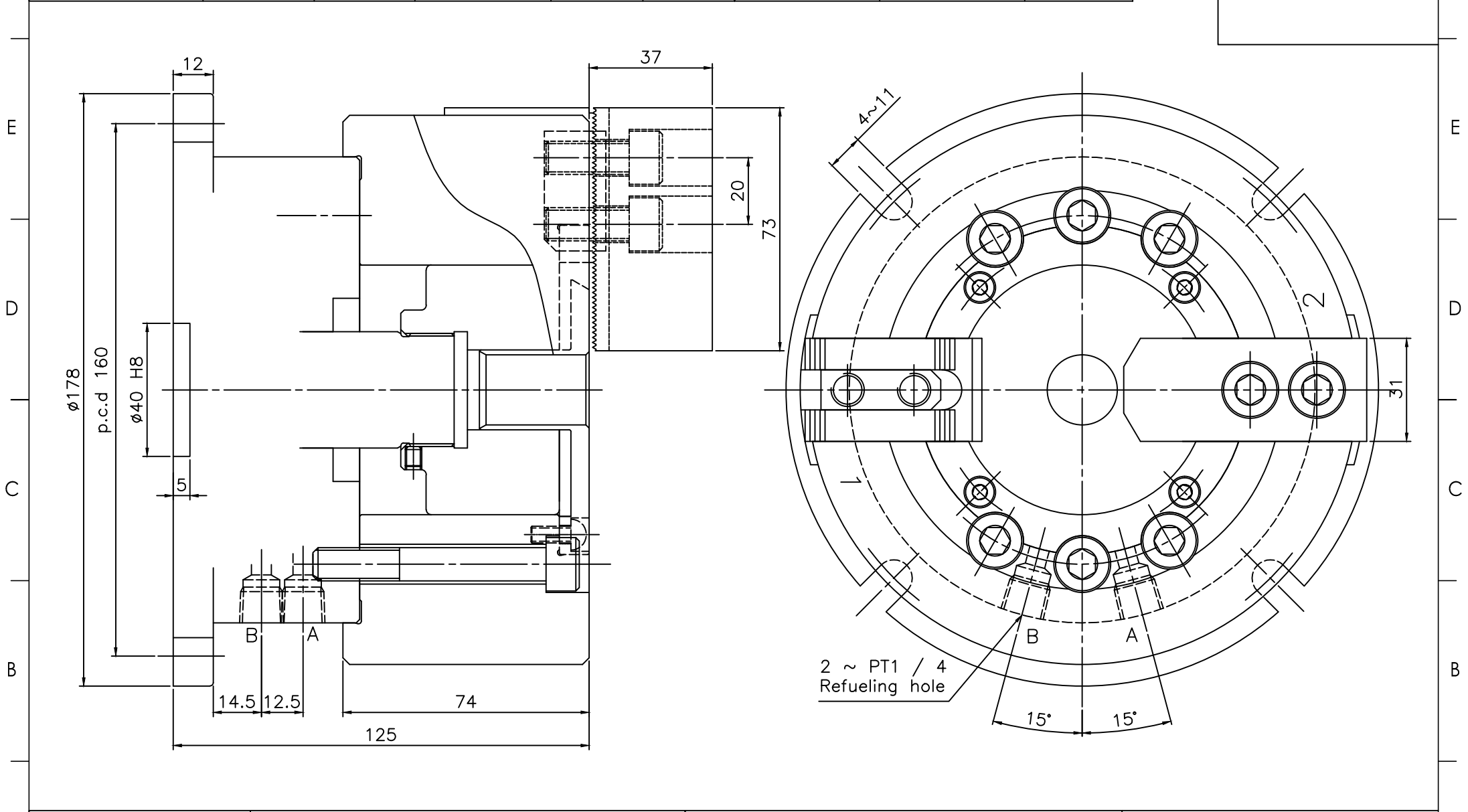

8	7		6	5		4	3	2	1
	Spec.	Eff. piston area cm ²		Chuck Dia. mm					
Model	Extend	Retract	Jaw Stroke (Dia.)	Max.	min.	Max clamping force	Max. pressure	Weight	Confirmed
VP-206	63.1	53.5	8.5	165	14	3570	23	18.3	



<p>LEADER CHUCK INTERNATIONAL +44 (0) 1827 700000 +353 (0)1 254 2555 INFORMATION@LEADERCHUCK.COM LEADERCHUCK.COM</p>	<p>TITLE: 2 Jaw Closed Centre Self Contained Power Chuck</p>	<p>DRAWING NO.: A3 \ AG-VP-206</p>	
--	--	---	---