

| 8 | 7 | | 6 | 5 | | 4 | | | 3 | | 2 | 1 |
|--------|--------|----------------------------------|-------------------|---------------|------|--------------------|--------------------|--------|-----------|--|---|---|
| | Spec. | Eff. piston area cm ² | | Chuck Dia. mm | | kgf | kg/cm ² | kg | Confirmed | | | |
| Model | Extend | Retract | mm | Max. | min. | Max clamping force | Max. pressure | Weight | | | | |
| VH-306 | 103.1 | 94.4 | Jaw Stroke (Dia.) | 168 | 15 | 5800 | 23 | 20.2 | | | | |

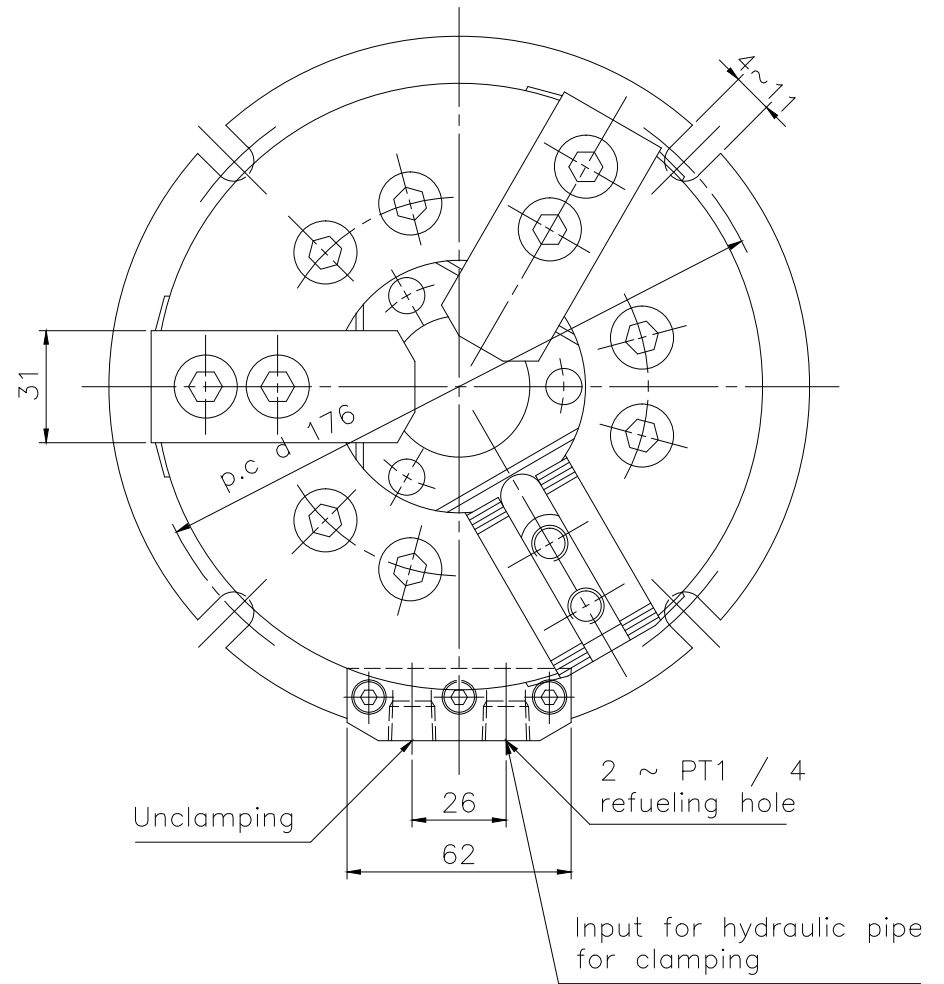
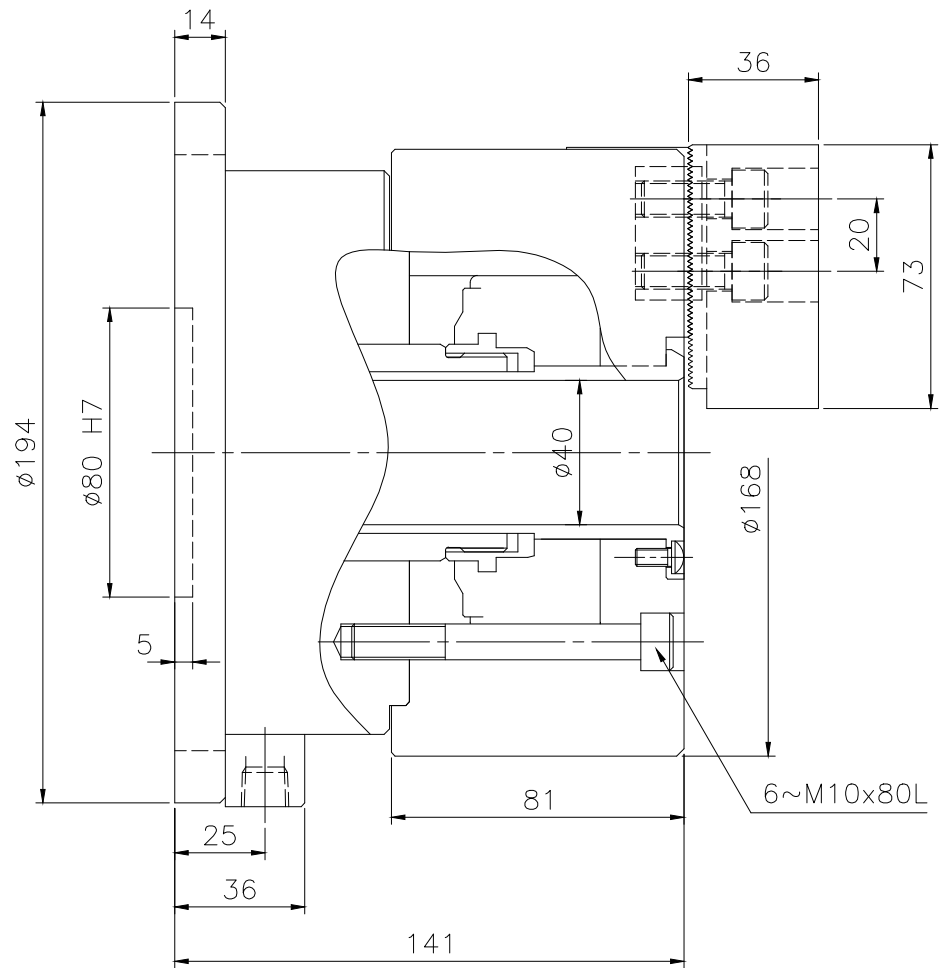

LEADER CHUCK INTERNATIONAL
+44 (0) 1827 700000
+353 (0)1 254 2555
INFORMATION@LEADERCHUCK.COM
LEADERCHUCK.COM

TITLE:
3 Jaw Open Centre Self
Contained Power Chuck

DRAWING NO.:
A3\AG-VH-306

