

8	7		6	5		4		3	2	1
	Spec.	Eff. piston area cm <sup>2</sup>		Chuck Dia. mm		kgf	kg/cm <sup>2</sup>			
	Model	Extend	Retract	Jaw Stroke (Dia.)	Max.	min.	Max clamping force	Max. pressure	Weight	Confirmed
F	VH-305	66	58.9	5.4	135	12	3650	29.7	11.9	

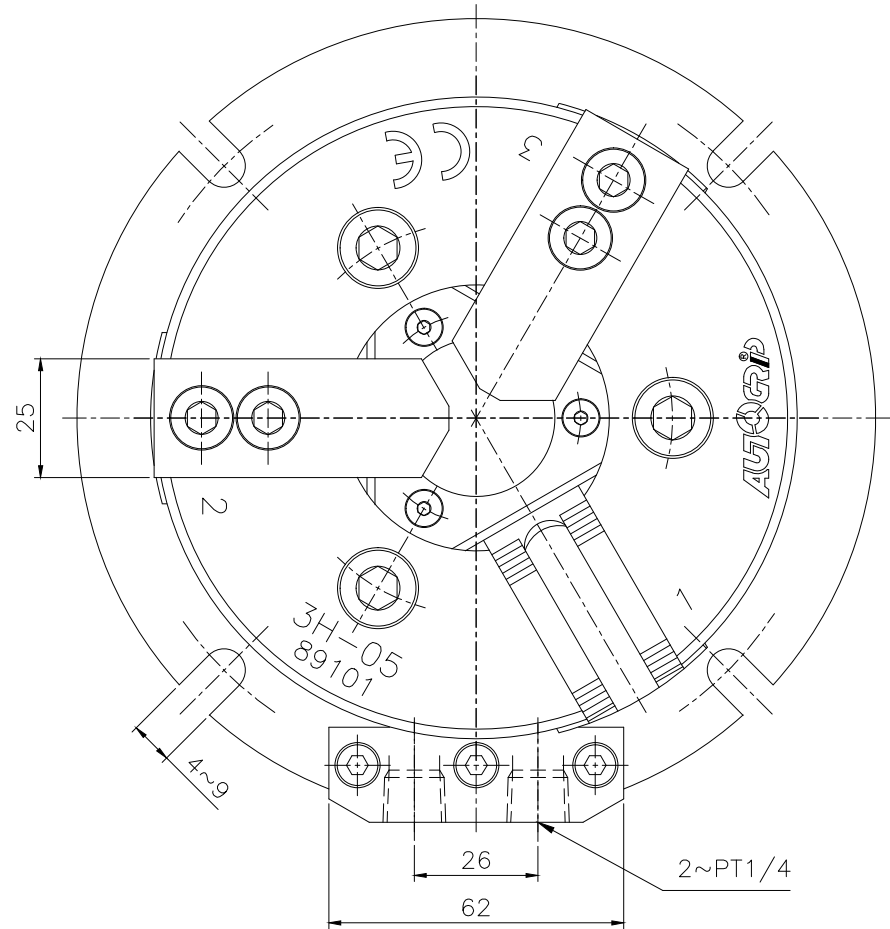
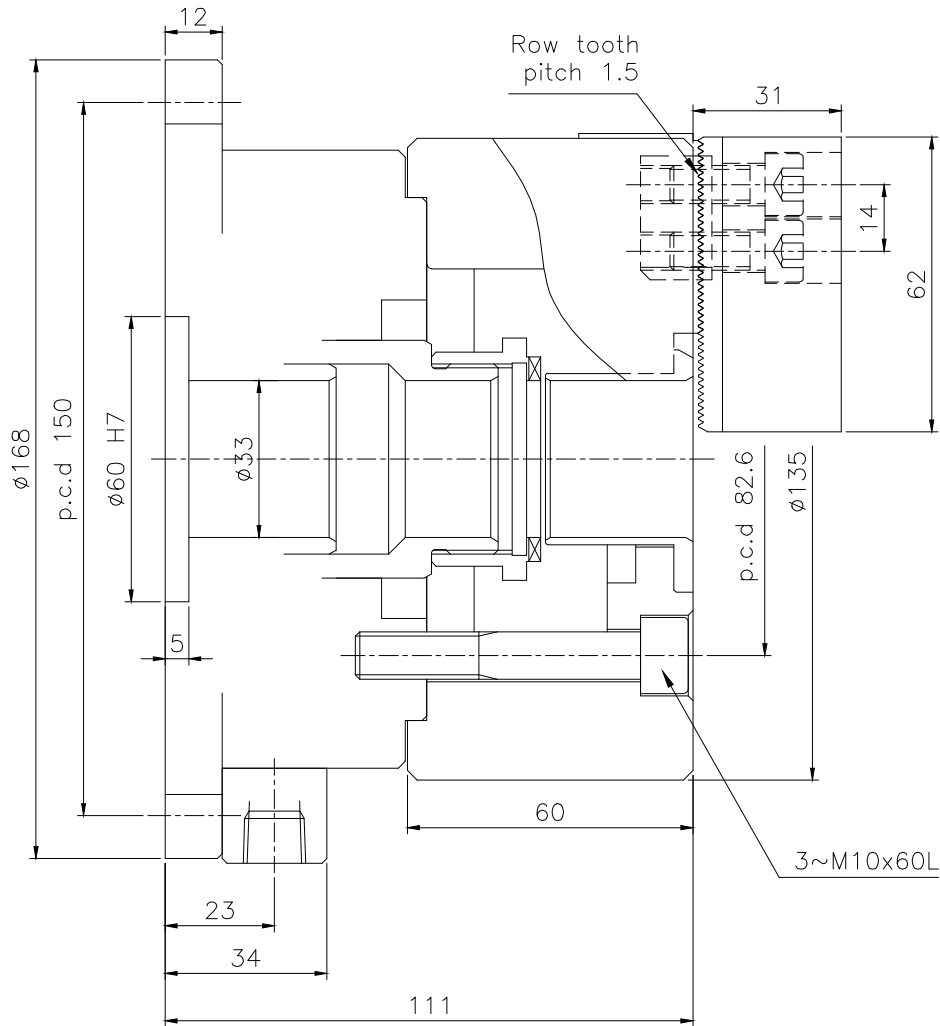

LEADER CHUCK INTERNATIONAL  
+44 (0) 1827 700000  
+353 (0)1 254 2555  
INFORMATION@LEADERCHUCK.COM  
LEADERCHUCK.COM

TITLE:  
3 Jaw Open Centre Self  
Contained Power Chuck

DRAWING NO.:  
A3\AG-VH-305

