

8	7		6	5		4		3	2	1
Spec.	Eff. piston area cm ²		mm	Chucking Dia. mm		kgf	kg/cm ²	kg	Confirmed	
Model	Extend	Retract	Jaw Stroke (Dia.)	Max.	min.	Max clamping force	Max. pressure	Weight		
VH-304	49.7	46.5	5.4	110	7	2900	30	8.1		

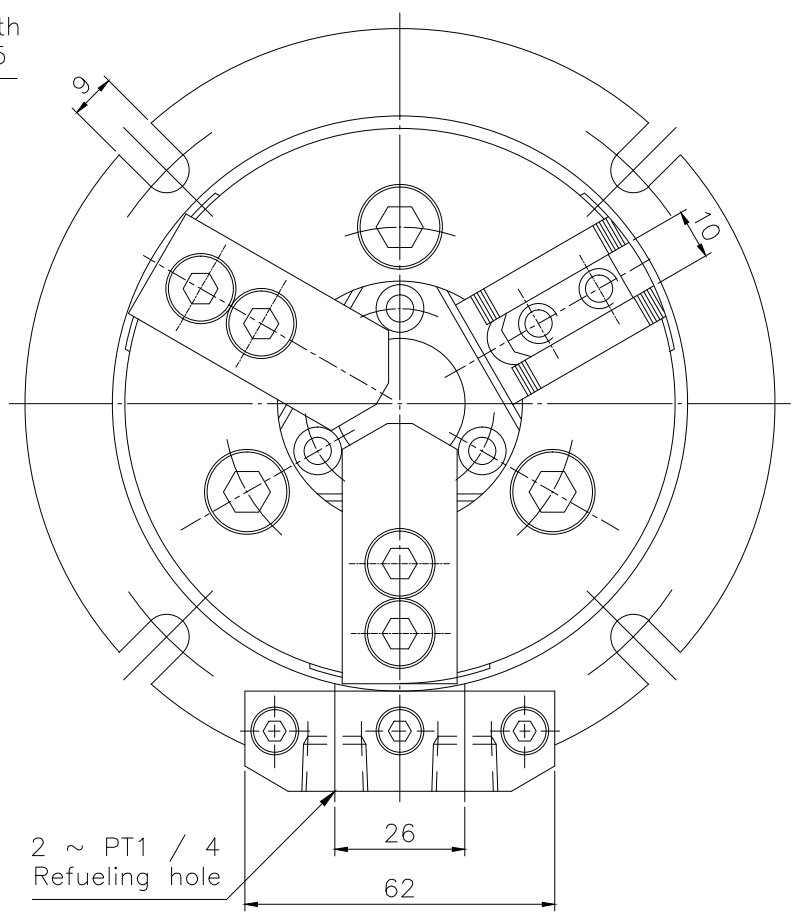
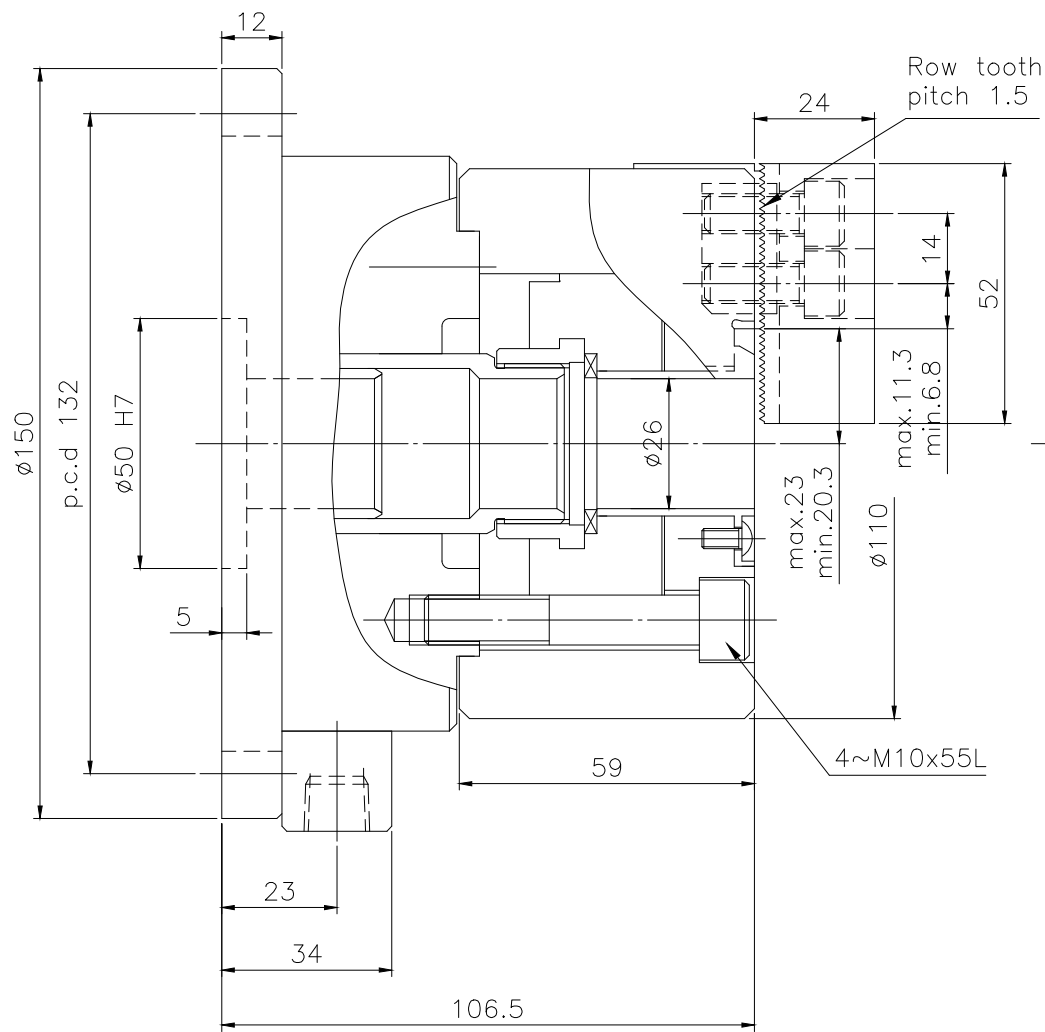

LEADER CHUCK INTERNATIONAL
+44 (0) 1827 700000
+353 (0)1 254 2555
INFORMATION@LEADERCHUCK.COM
LEADERCHUCK.COM

TITLE:
3 Jaw Open Centre Self
Contained Power Chuck

DRAWING NO.:
A3\AG-VH-304

