

8	7		6	5		4	3	2	1	
	Spec.	Eff. piston area cm ²		Chucking Dia. mm						kgf
	Model	Extend	Retract	Jaw Stroke (Dia.)	Max.	min.	Max clamping force	Max. pressure	Weight	Confirmed
F	VH-204	49.7	46.5	5.4	110	7	1930	20	7.9	

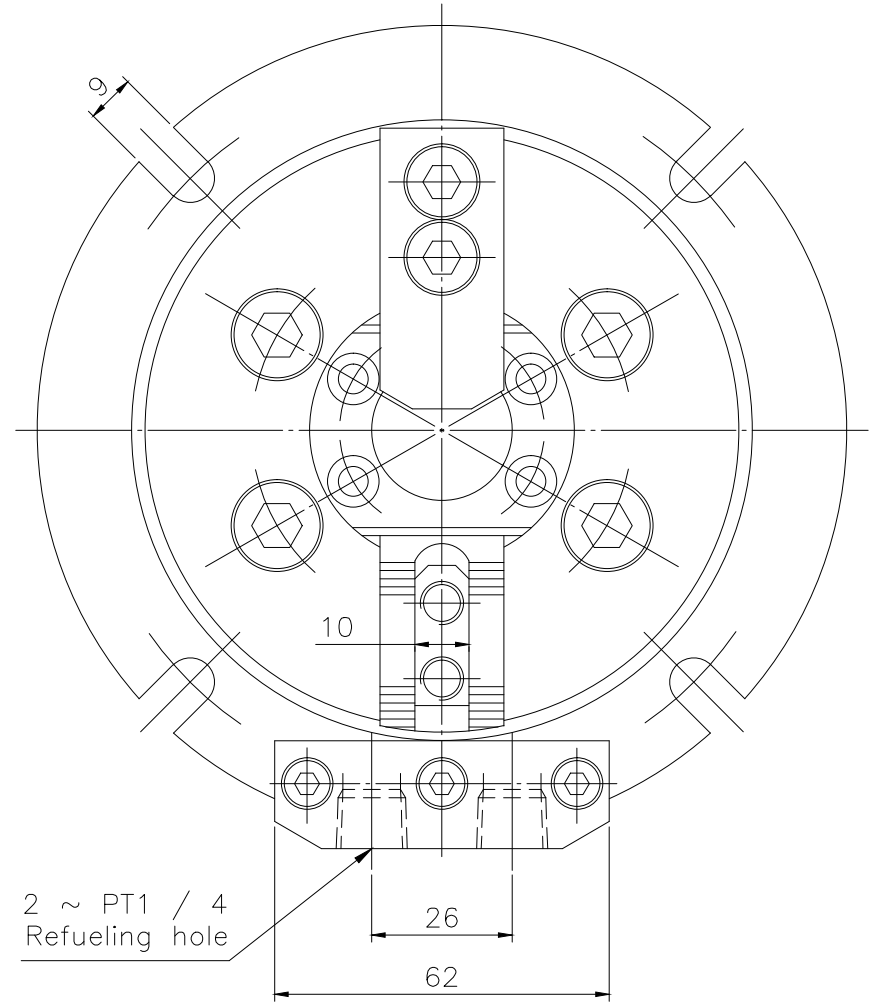
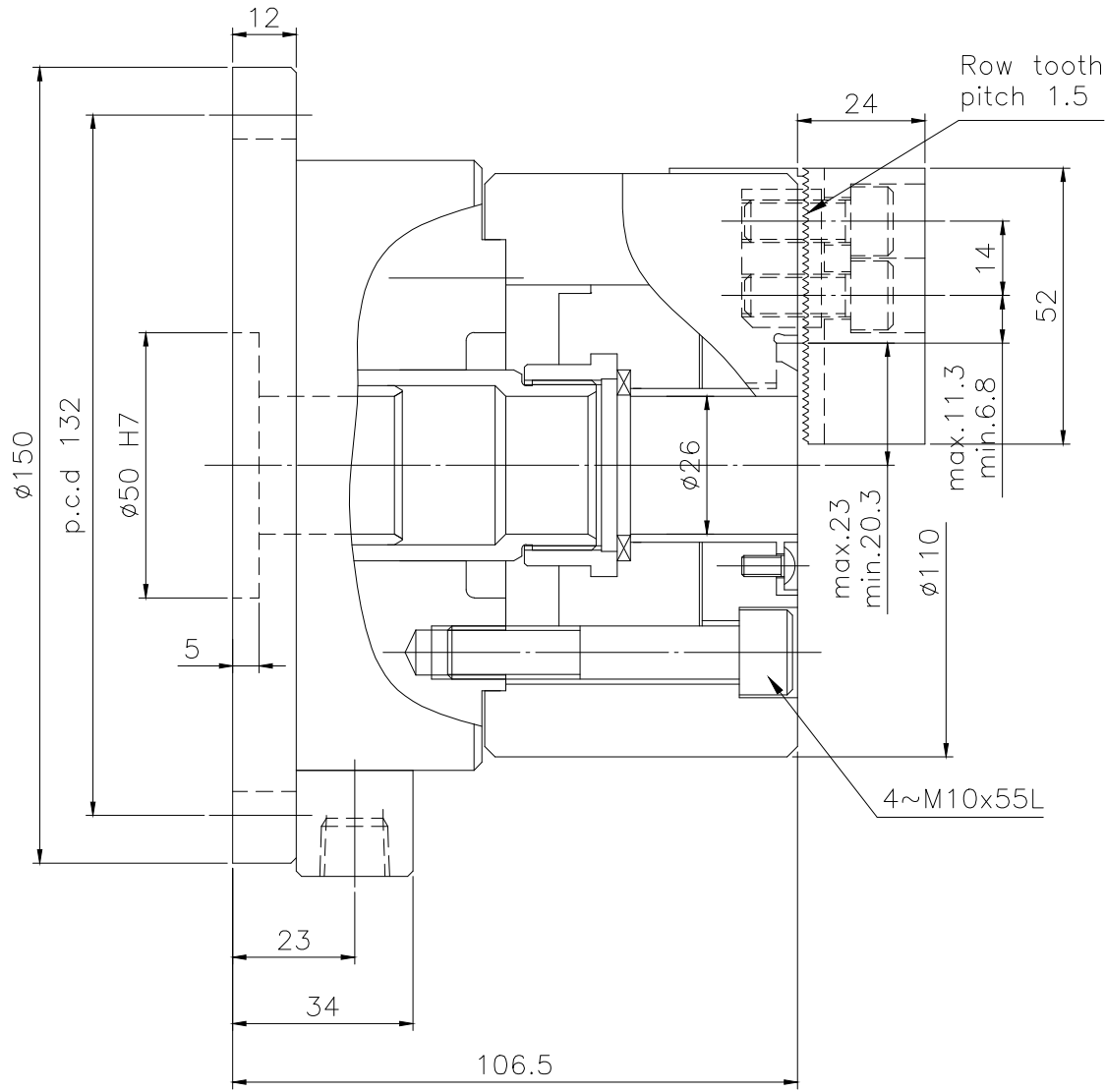

LEADER CHUCK INTERNATIONAL
+44 (0) 1827 700000
+353 (0)1 254 2555
INFORMATION@LEADERCHUCK.COM
LEADERCHUCK.COM

TITLE:
2 Jaw Open Centre Self
Contained Power Chuck

DRAWING NO.:
A3 \ AG-VH-204

