

6	5	4	3	2	1						
Spec.	mm	Chucking Dia. mm		Max gripping force kN		Max pressure kg/cm ²		kg/cm ²	(use pressure 6.0kgf/cm ²) lit	kg	Confirmed
Model	Jaw Stroke (Dia.)	Max.	min.	Pneumatic at 6.0kgf/cm ²	Hydraulic at 13.0kgf/cm ²	Air Pressure Pneumatic	Oil Pressure Hydraulic	Min. pressure	Air consumption (at 6.0 kgf/cm ²)	Weight	
SD-306	7.2	165	35	11.5	25	6	13	2	0.58	20.6	

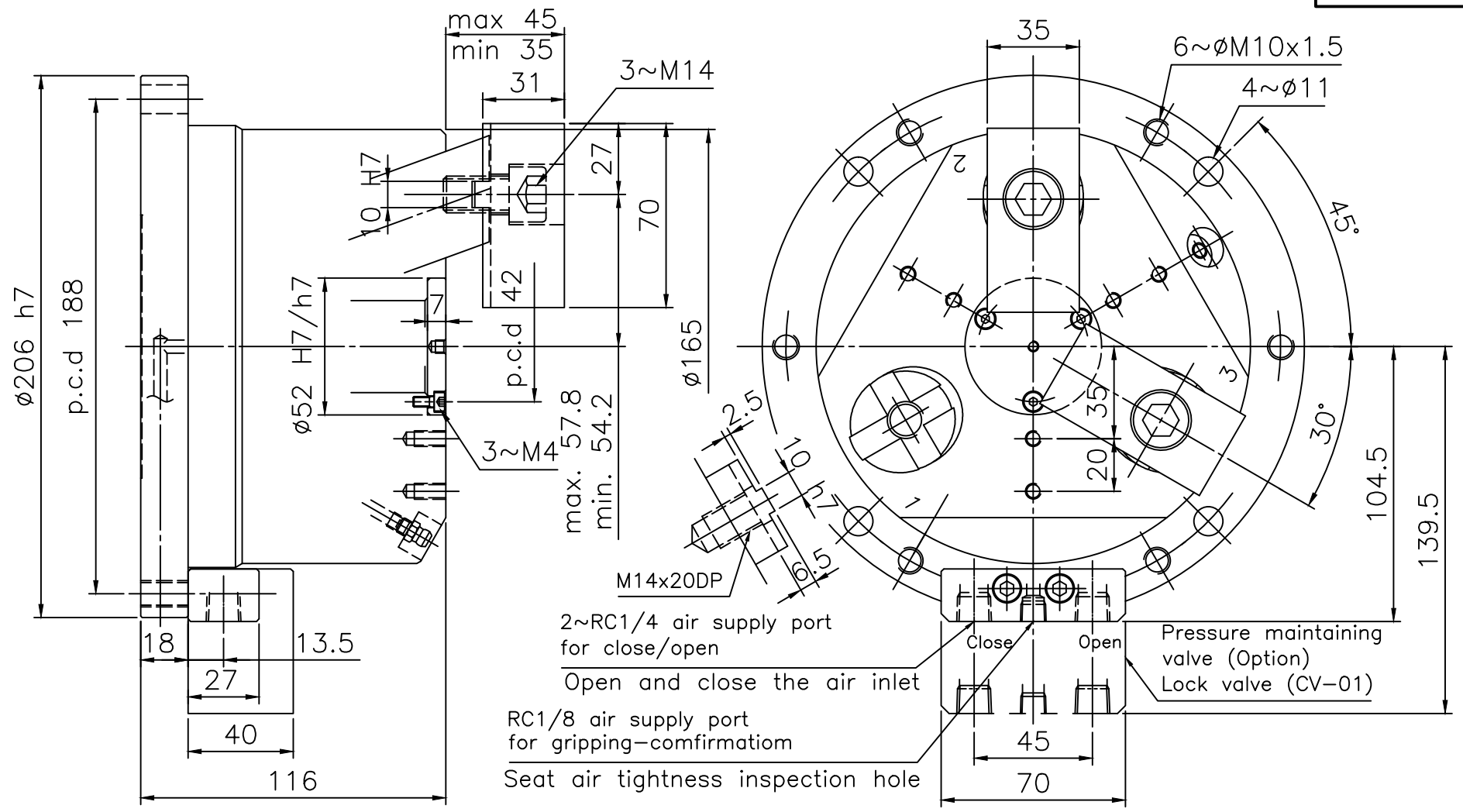

LEADER CHUCK INTERNATIONAL
+44 (0) 1827 700000
+353 (0)1 254 2555
INFORMATION@LEADERCHUCK.COM
LEADERCHUCK.COM

TITLE:
3 Jaw Partial Open Centre Self Contained
Hydraulic or Pneumatic Pull Down Power Chuck
with Simultaneous Radial & Axial Clamping

DRAWING NO.:
A4 \ AG - SD - 306



6	5	4	3	2	1
---	---	---	---	---	---