

Spec.	mm	Chucking Dia. mm		Max gripping force kN		Max pressure kg/cm ²		kg/cm ²	(use pressure 6.0kgf/cm ²) lit	kg	Confirmed
		Model	Jaw Stroke (Dia.)	Max.	min.	Pneumatic at 6.0kgf/cm ²	Hydraulic at 13.0kgf/cm ²	Air Pressure Pneumatic			
SD-304	5	110	18	5	10.9	6	13	2	0.26	8.1	

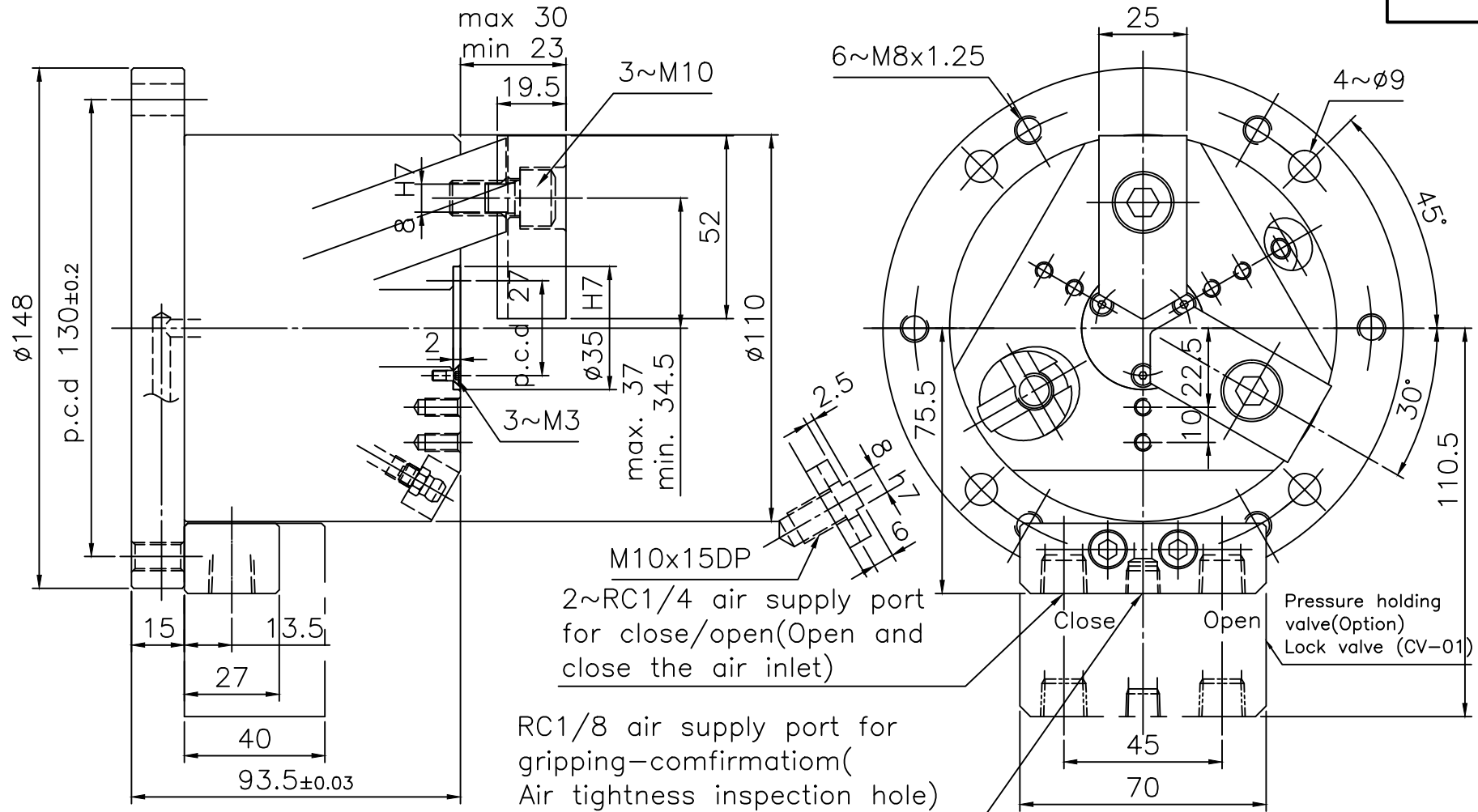

LEADER CHUCK INTERNATIONAL
+44 (0) 1827 700000
+353 (0)1 254 2555
INFORMATION@LEADERCHUCK.COM
LEADERCHUCK.COM

TITLE:
3 Jaw Partial Open Centre Self Contained
Hydraulic or Pneumatic Pull Down Power Chuck
with Simultaneous Radial & Axial Clamping

DRAWING NO.:
A4 \ AG-SD-304

