

Spec. Model	mm	mm	Chucking Dia. mm		kgf	kgf	r.p.m.	kg
	Plunger Stroke	Jaw Stroke (Dia.)	Max.	min.	Max D.B. pull	Max clamping force	Max speed	Weight
CL-80	6	-	80	20	3500	7300	4000	17.8

Confirmed

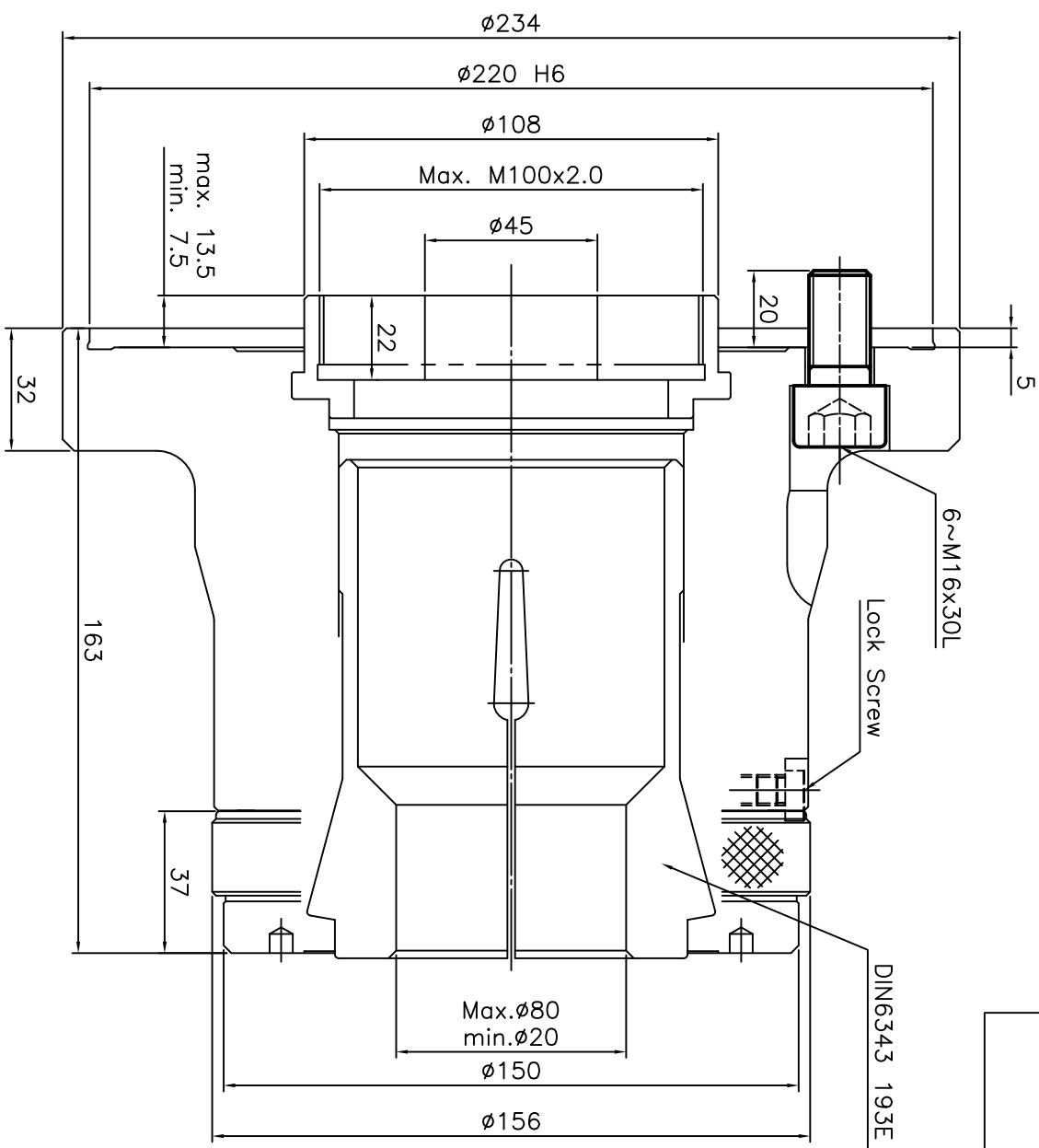
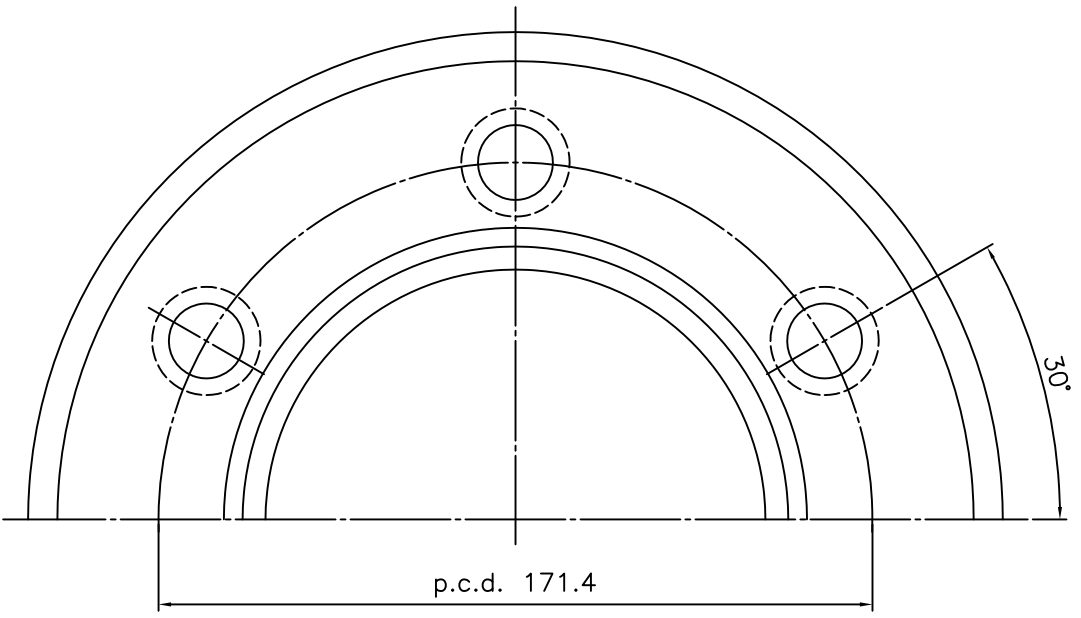

LEADER CHUCK INTERNATIONAL
+44 (0) 1827 700000
+353 (0)1 254 2555
INFORMATION@LEADERCHUCK.COM
LEADERCHUCK.COM

TITLE:
Collet Chuck

DRAWING NO.:
A4 \ AG-CL-80

