

6	Spec. Model	mm	Punger Stroke	mm	Jaw Stroke (Dia.)	Chucking Dia. mm		kgf	Max D.B. pull	kgf	Max clamping force	r.p.m.	Max speed	kg · m ²	kg	Weight	Confirmed
	CL-60A6					6	-										
D																	

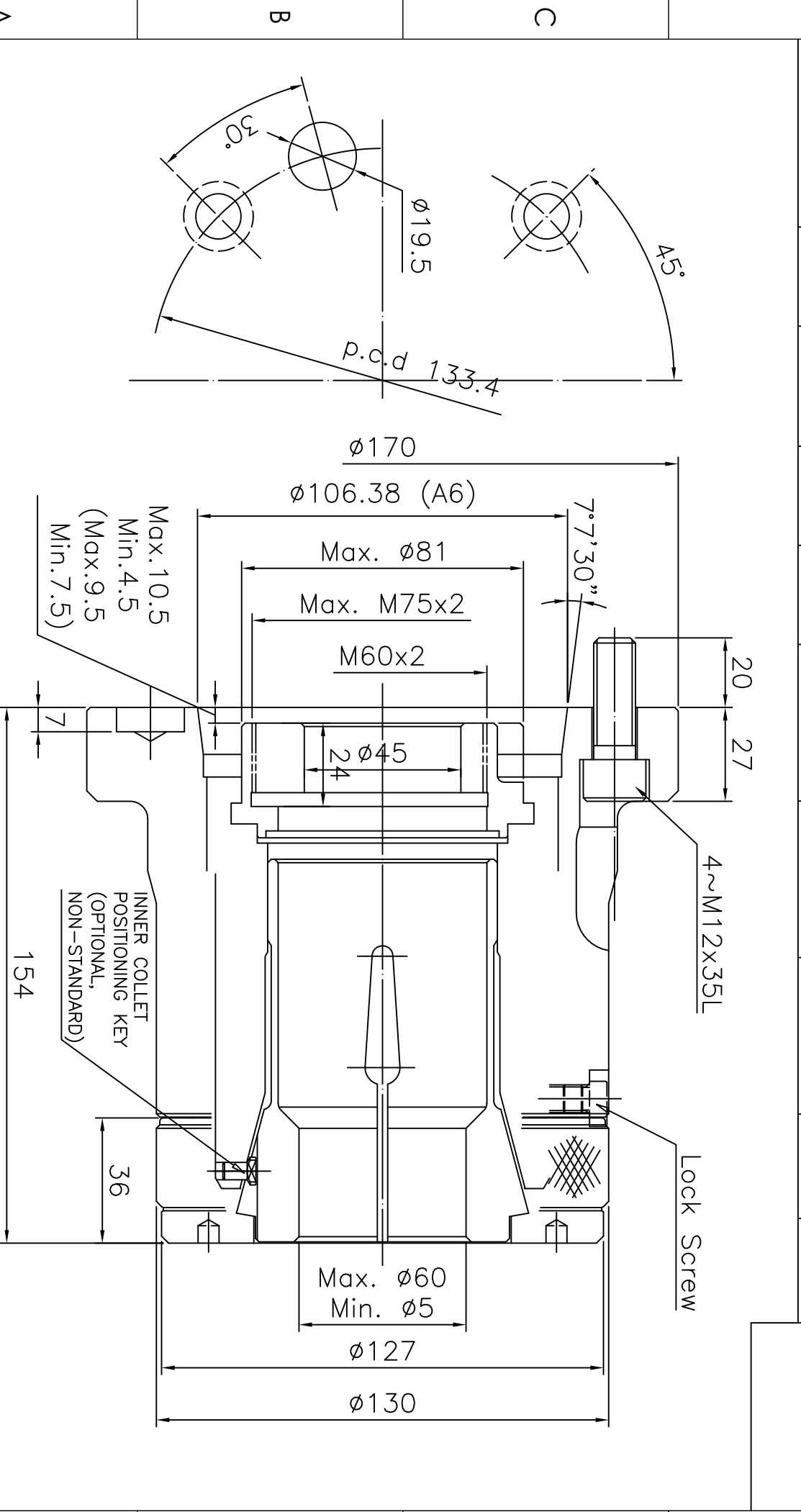

LEADER CHUCK INTERNATIONAL
+44 (0) 1827 700000
+353 (0)1 254 2555
INFORMATION@LEADERCHUCK.COM
LEADERCHUCK.COM

TITLE: Collet Chuck

DRAWING NO.: A4 \ AG-CL-60A6

LEADER CHUCK INTERNATIONAL