

	6	5		4		3		2		1	
	Spec.	mm	mm	Chucking Dia. mm		kgf	kgf	r.p.m.	l	kg	Confirmed
	Model	Plunger Stroke	Jaw Stroke (Dia.)	Max.	min.	Max D.B. pull	Max clamping force	Max speed	kg m ²	Weight	
D	CL-42	6	—	42	3	2500	5400	6000	0.06	6.9	D

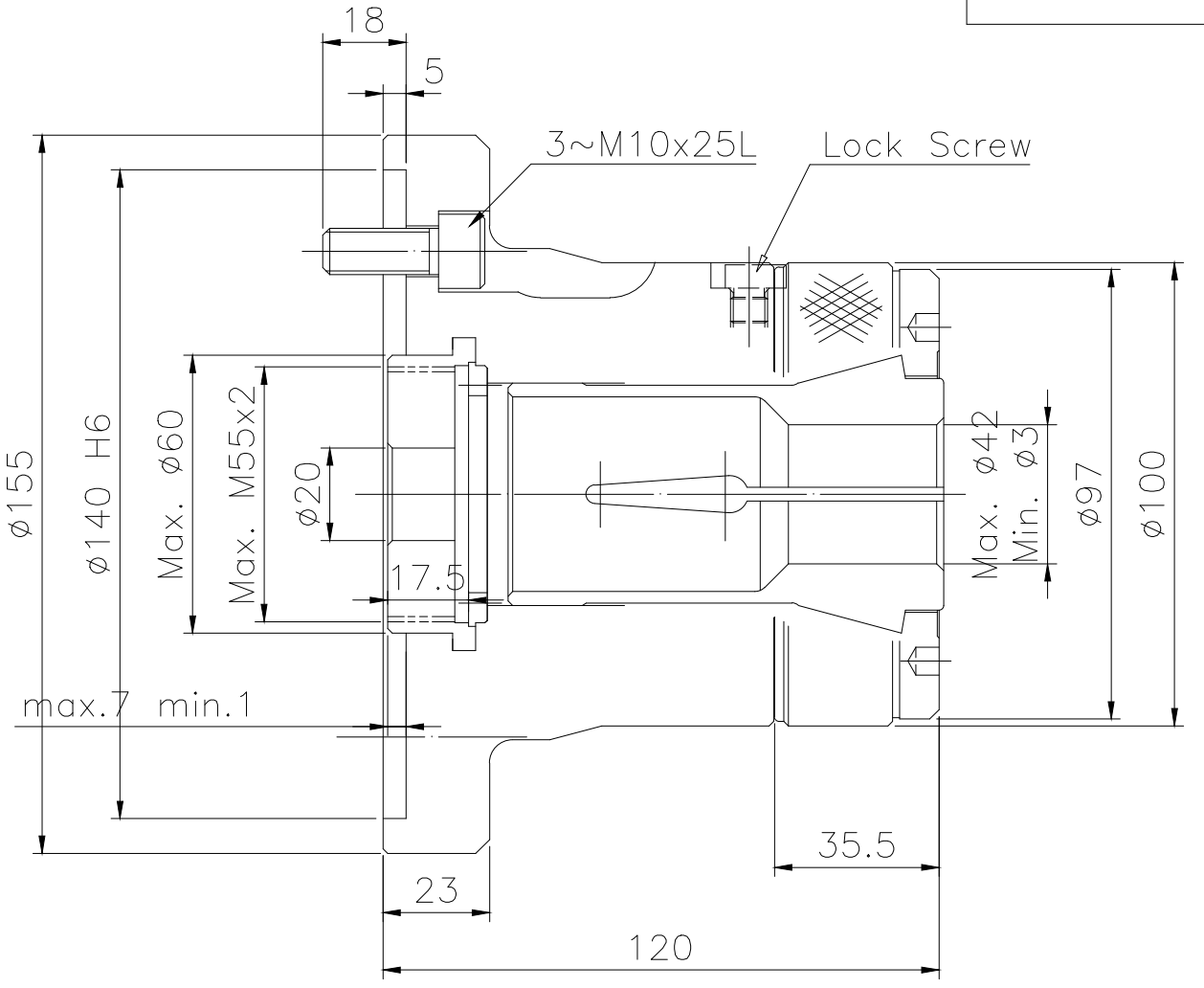
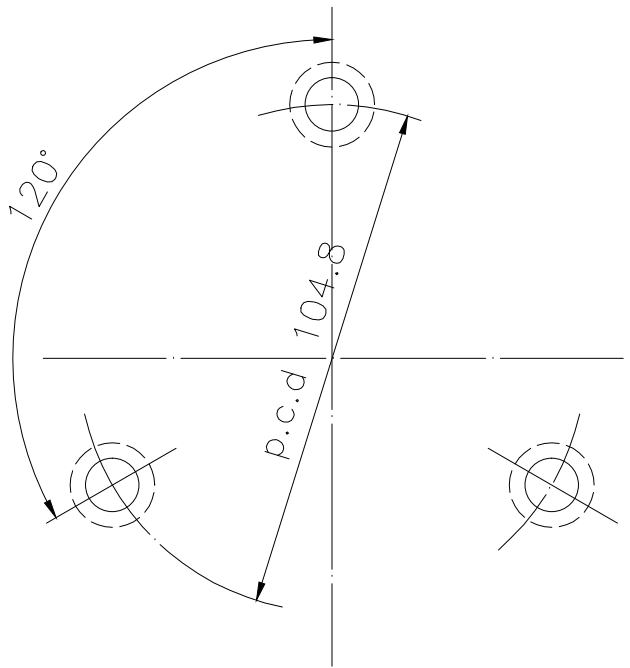

LEADER CHUCK INTERNATIONAL
+44 (0) 1827 700000
+353 (0)1 254 2555
INFORMATION@LEADERCHUCK.COM
LEADERCHUCK.COM

TITLE:
Collet Chuck

DRAWING NO.:
A4\AG-CL-42



	6	5	4	3	2	1
--	---	---	---	---	---	---