

Spec.	7		6		5		4		3		2		1	
	mm	mm	Gripping Dia. mm		Allowable hydraulic cylinder thrust kgf	Maximum clamping force kgf	Maximum number of revolutions r.p.m.	l	weight	Confirmed				
Model	Plunger Stroke	Jaw Stroke (Dia.)	Max.	min.	Max D.B. pull	Max clamping force	Max speed	kg m ²	kg · m ²					
4T-15	25	19.6	381	60	2780	10750	1200	2.25	118.3					

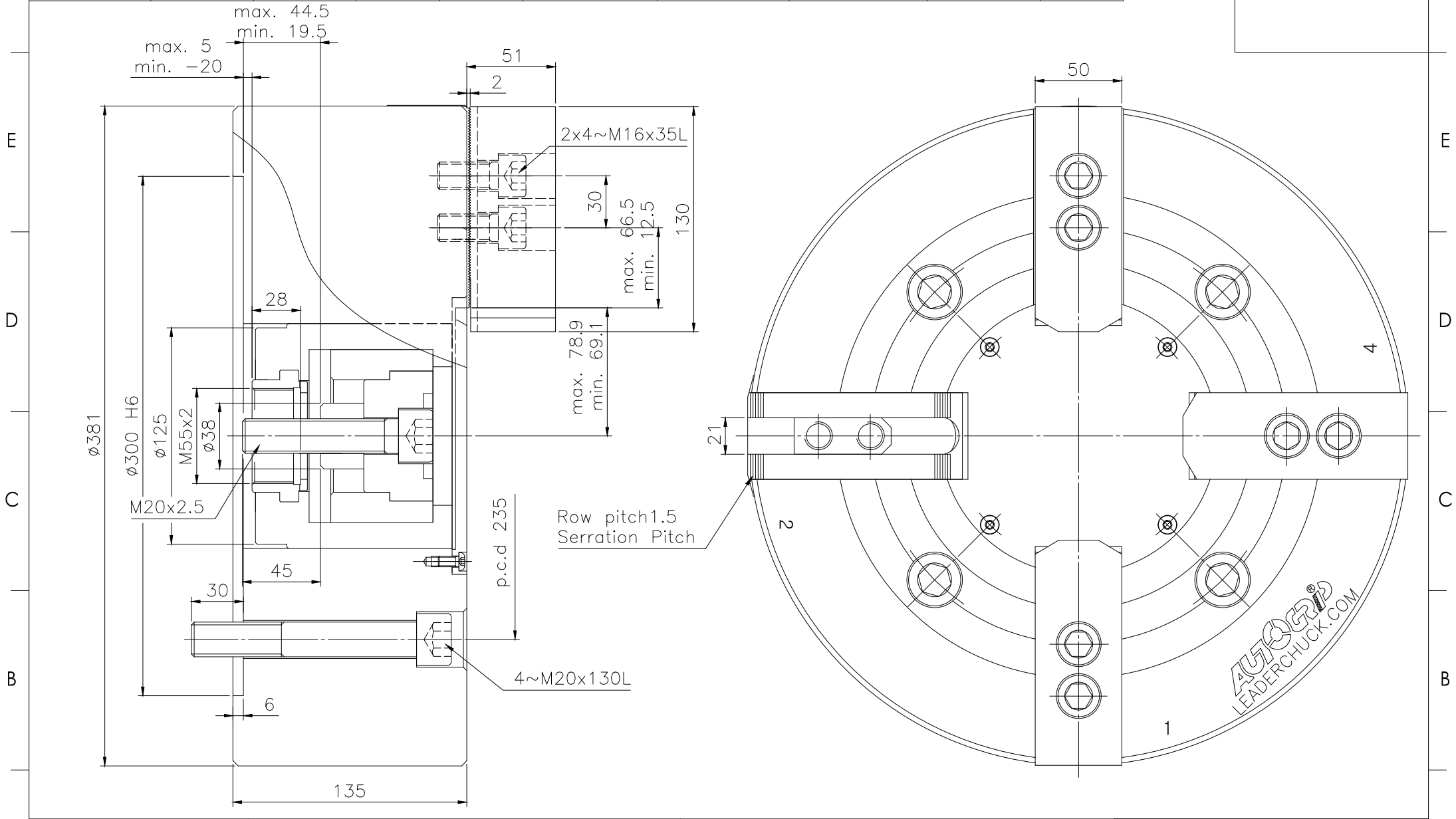

LEADER CHUCK INTERNATIONAL +44 (0) 1827 700000 +353 (0)1 254 2555 INFORMATION@LEADERCHUCK.COM LEADERCHUCK.COM	TITLE: Four-jaw two motion type power chucks	DRAWING NO.: A3\AG-4T-15	
---	--	-----------------------------	--