

8	7	6	5		4		3		2		1	
			Gripping Dia. mm		Allowable hydraulic cylinder thrust kgf Max D.B. pull	Maximum clamping force kgf Max clamping force	Maximum number of revolutions r.p.m. Max speed	GD ² kg m ²	weight kg · m ²	Confirmed		
Spec.	mm Plunger Stroke	mm Jaw Stroke (Dia.)	Max.	min.								
F 4T-10	20	16	254	50	2200	8100	2100	0.35	44.3			

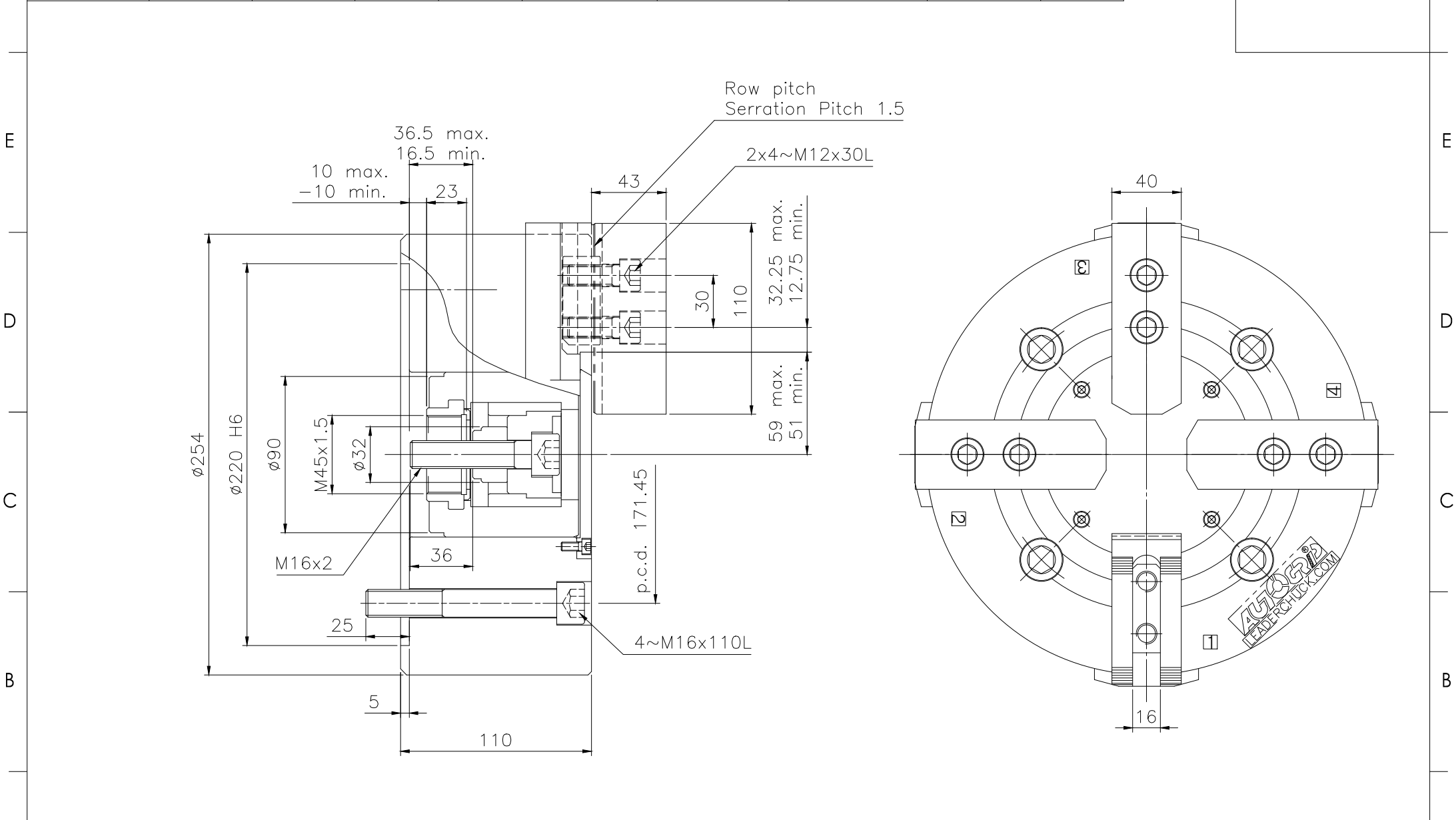

LEADER CHUCK INTERNATIONAL +44 (0) 1827 700000 +353 (0)1 254 2555 INFORMATION@LEADERCHUCK.COM LEADERCHUCK.COM		TITLE: Double acting four-jaw chuck	DRAWING NO.: A3\AG-4T-10	
---	--	---	-----------------------------	--