

| 8 | 7 | | 6 | | 5 | 4 | 3 | 2 | 1 | |
|-----------|----------------|-------------------|------|------------------|---------------|--------------------|-----------|-------------------|--------|-----------|
| | Spec. | mm | mm | Chucking Dia. mm | | kgf | kgf | r.p.m. | | l |
| Model | Plunger Stroke | Jaw Stroke (Dia.) | Max. | min. | Max D.B. pull | Max clamping force | Max speed | kg m ² | Weight | Confirmed |
| 3P-218A11 | 35 | 16 | 450 | 60 | 8360 | 25400 | 2800 | 2.32 | 130 | |

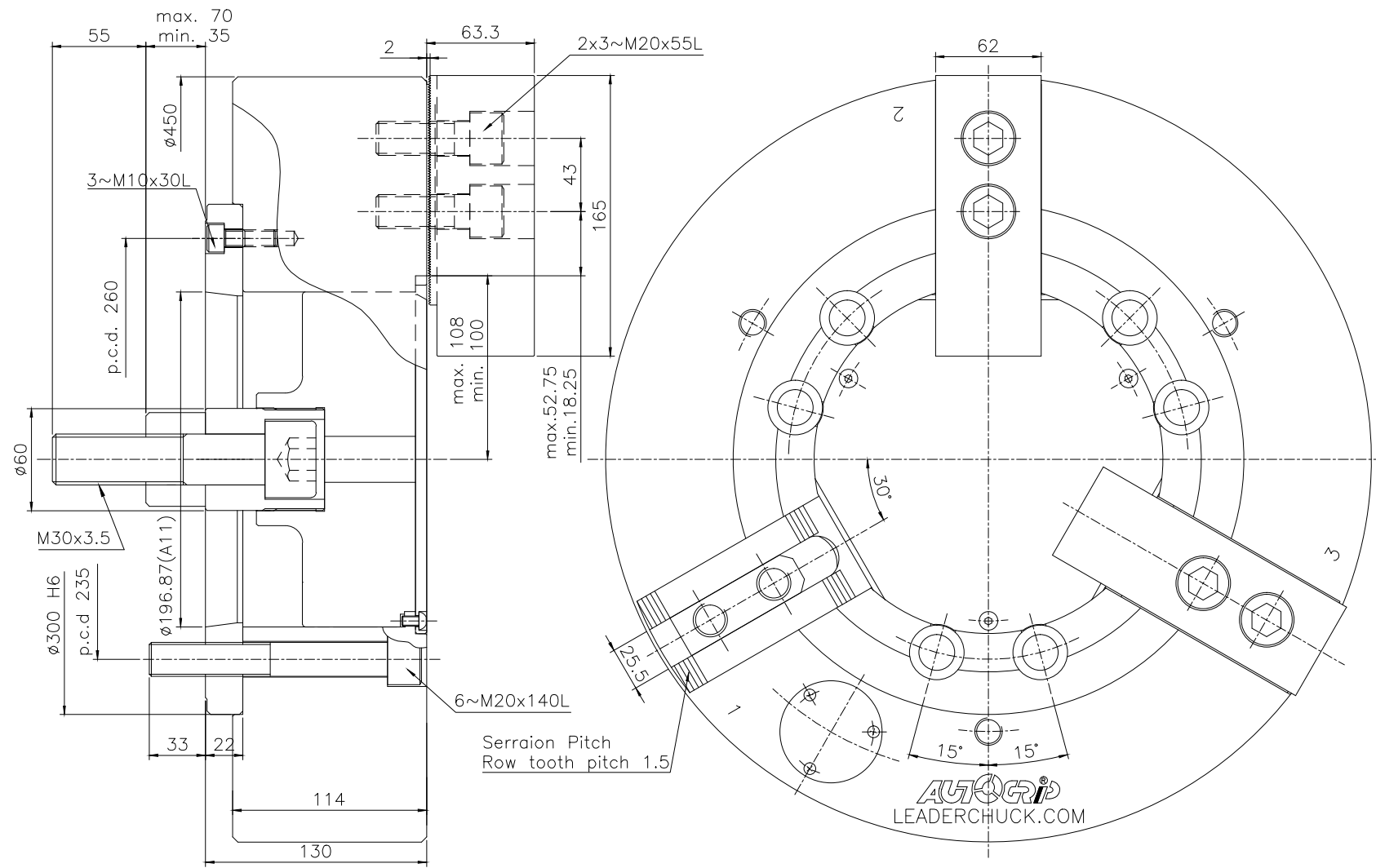

LEADER CHUCK INTERNATIONAL
+44 (0) 1827 700000
+353 (0)1 254 2555
INFORMATION@LEADERCHUCK.COM
LEADERCHUCK.COM

TITLE:
Zhongshi three-jaw chuck

DRAWING NO.:
A3\AG-3P-218A11

