

8	7		6		5	4	3	2		1
	Spec.	mm	mm	Chucking Dia. mm		kgf	kgf	r.p.m.	l	kg
Model	Plunger Stroke	Jaw Stroke (Dia.)	Max.	min.	Max D.B. pull	Max clamping force	Max speed	kg m <sup>2</sup>	Weight	Confirmed
3P-215A8	35	16	381	50	8360	25390	3000	1.8	122.4	

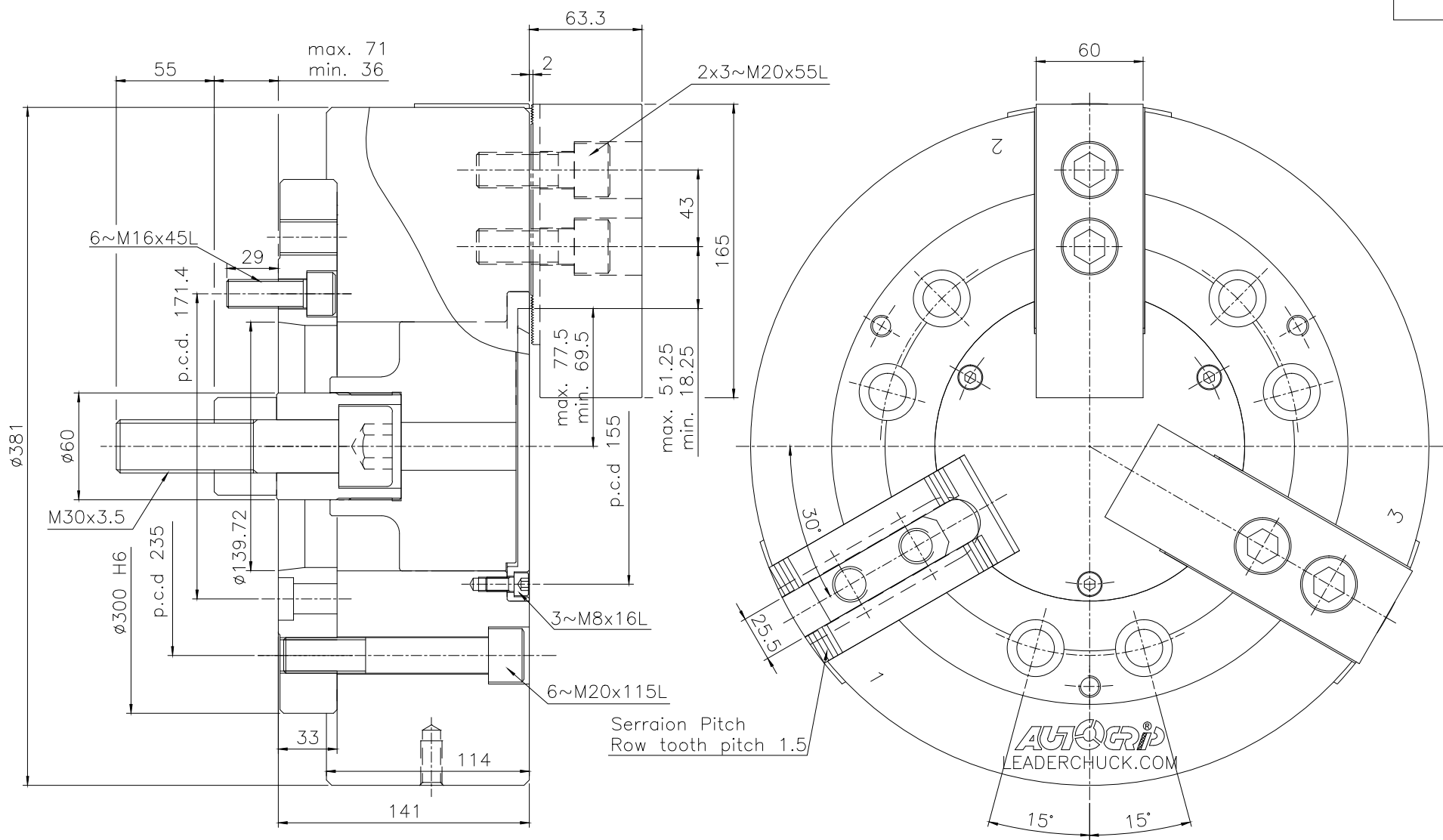

LEADER CHUCK INTERNATIONAL  
+44 (0) 1827 700000  
+353 (0)1 254 2555  
INFORMATION@LEADERCHUCK.COM  
LEADERCHUCK.COM

TITLE:  
Non-thru hole  
power chuck

DRAWING NO.:  
A3\AG-3P-215A8

