

8	7		6		5	4	3	2	1	
	Spec.	mm	mm	Chuck Dia. mm		kgf	kgf	r.p.m.	l	kg
Model	Plunger Stroke	Jaw Stroke (Dia.)	Max.	min.	Max D.B. pull	Max clamping force	Max speed	kg m ²	Weight	Confirmed
3P-215	35	16	381	50	8360	25390	3000	1.8	109.9	

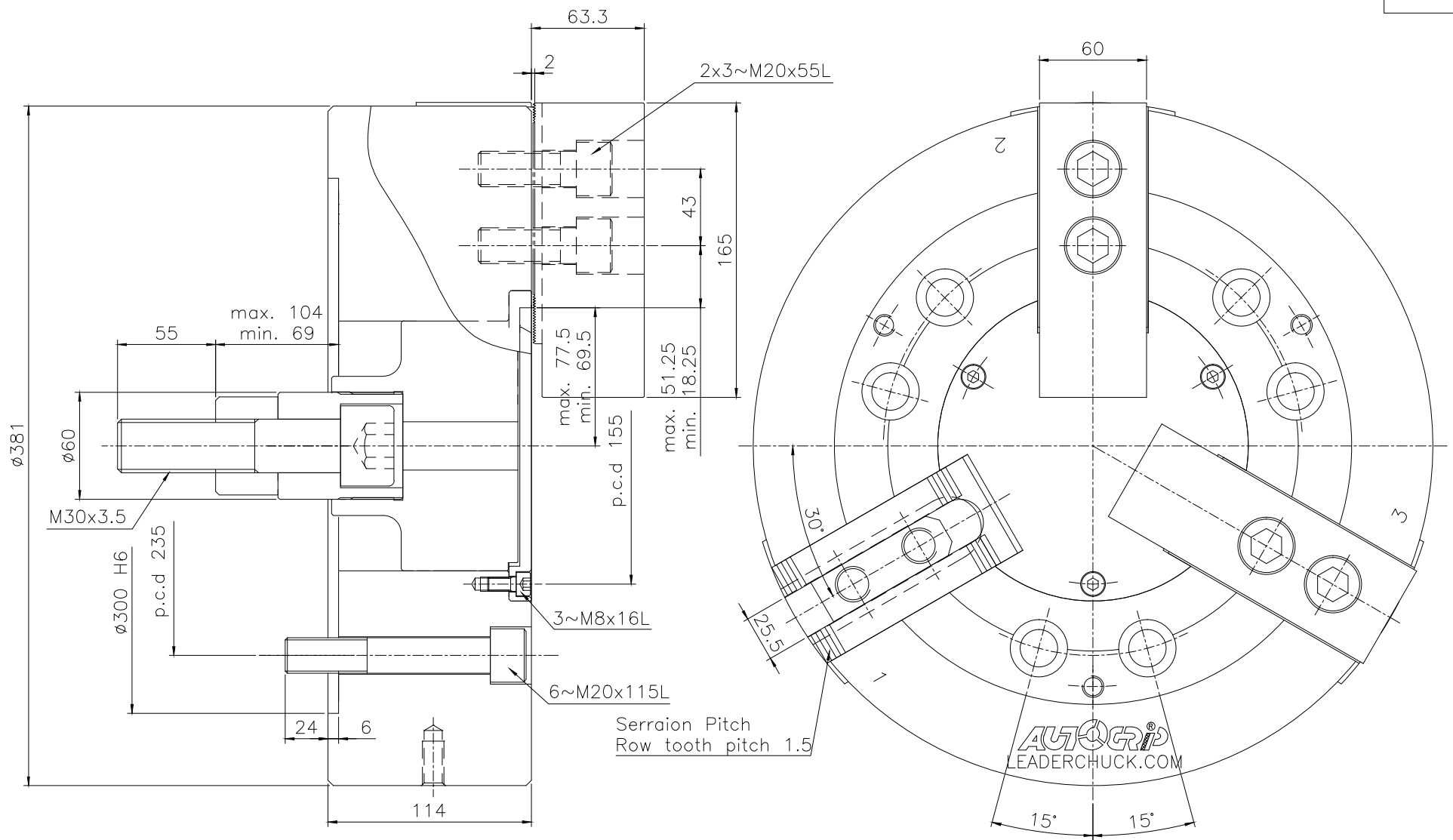

LEADER CHUCK INTERNATIONAL
+44 (0) 1827 700000
+353 (0)1 254 2555
INFORMATION@LEADERCHUCK.COM
LEADERCHUCK.COM

TITLE:
Non-thru hole
power chuck

DRAWING NO.:
A3\AG-3P-215

