

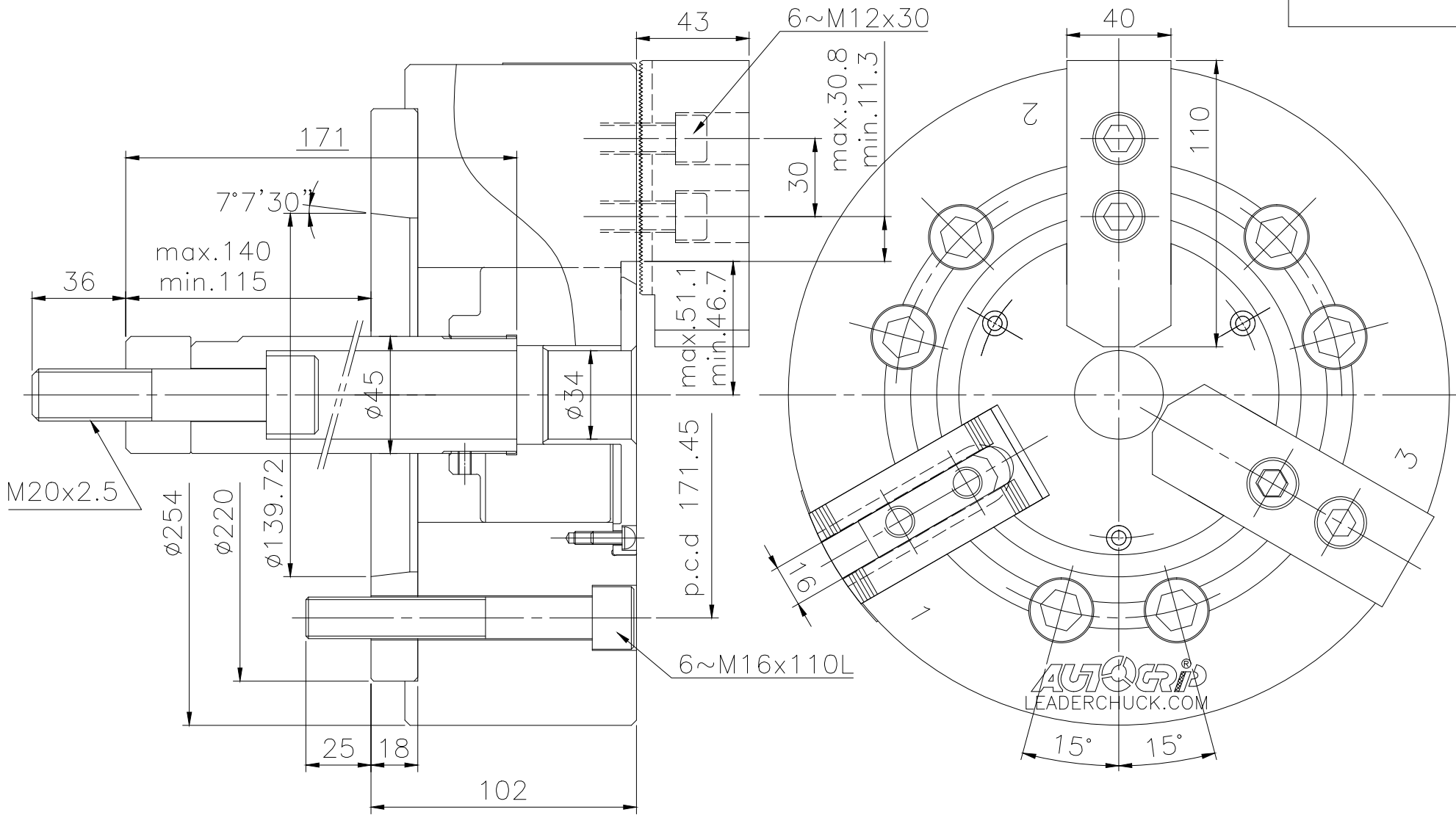

Spec.	mm	mm	Chucking Dia. mm		kgf	kgf	r.p.m.	l	kg	Confirmed
			Max.	min.						
Model	Plunger Stroke	Jaw Stroke (Dia.)								
3P-10A8	25	8.8	254	22	2950	11000	4000	0.30	40	



LEADER CHUCK INTERNATIONAL +44 (0) 1827 700000 +353 (0)1 254 2555 INFORMATION@LEADERCHUCK.COM LEADERCHUCK.COM	TITLE: Three-jaw real power chuck	DRAWING NO.: A4 \ AG-3P-10A8	
---	--------------------------------------	---------------------------------	---

6	5	4	3	2	1
---	---	---	---	---	---