

6	5		4		3		2		1	
Spec.	mm	mm	Chuck Dia. mm		kgf	kgf	r.p.m.	GD ²	kg	Confirmed
Model	Plunger Stroke	Jaw Stroke (Dia.)	Max.	min.	Max D.B. pull	Max clamping force	Max speed	kg m ²	Weight	
3P-08A6	21	8.8	210	17	2550	7600	4750	0.14	27	

D

D

C

C

B

B

A

A

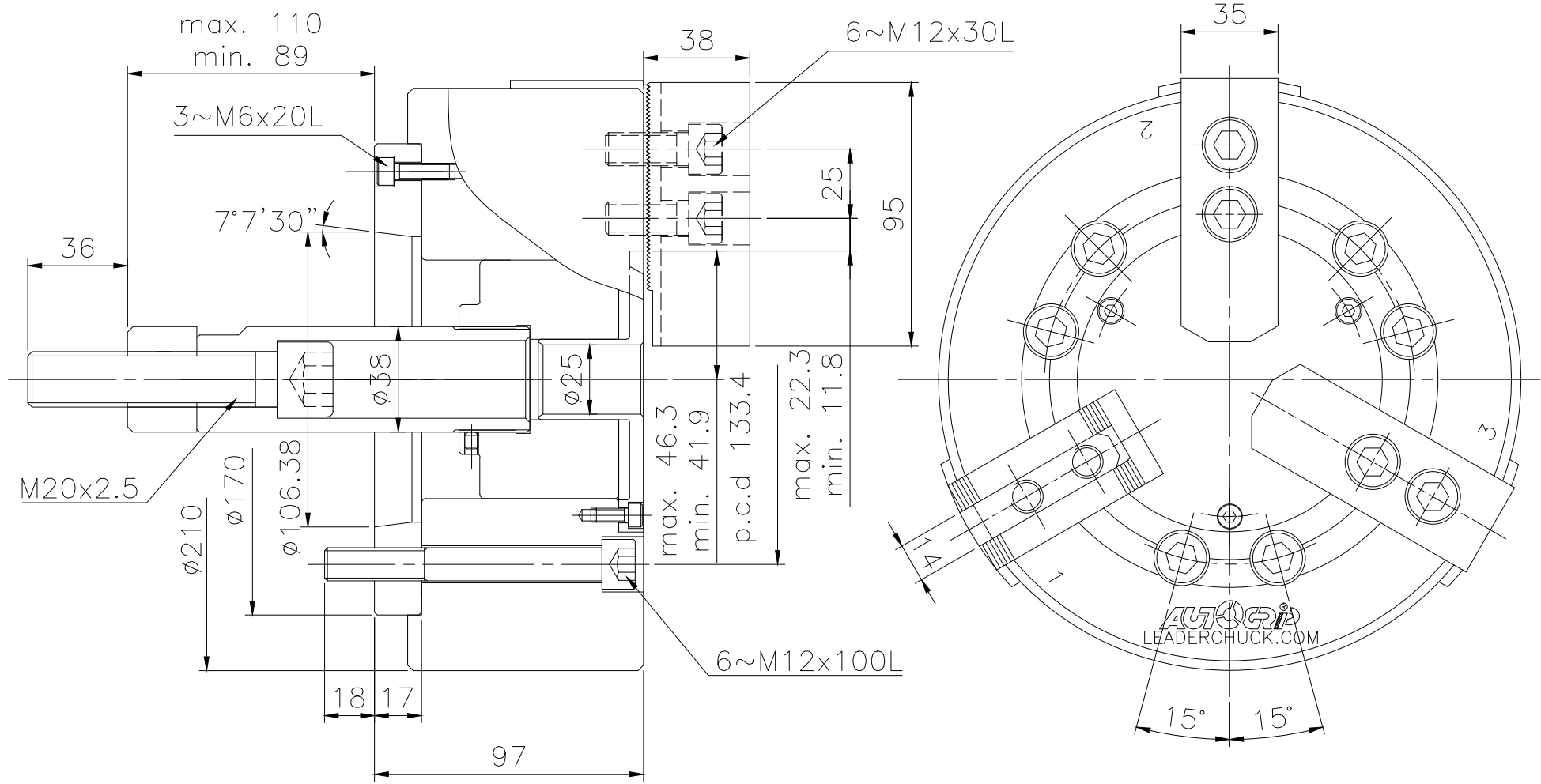

LEADER CHUCK INTERNATIONAL
+44 (0) 1827 700000
+353 (0)1 254 2555
INFORMATION@LEADERCHUCK.COM
LEADERCHUCK.COM

TITLE: Three-jaw real power chuck

DRAWING NO.: A4\AG-3P-08A6



6	5	4	3	2	1
---	---	---	---	---	---