

	6	5		4		3		2		1
	Spec.	mm	mm	Chucking Dia. mm		kgf	kgf	r.p.m.	l	kg
	Model	Plunger Stroke	Jaw Stroke (Dia.)	Max.	min.	Max D.B. pull	Max clamping force	Max speed	kg m ²	Weight
D	3P-08A5	21	8.8	210	17	2550	7600	4750	0.14	28
	Confirmed									

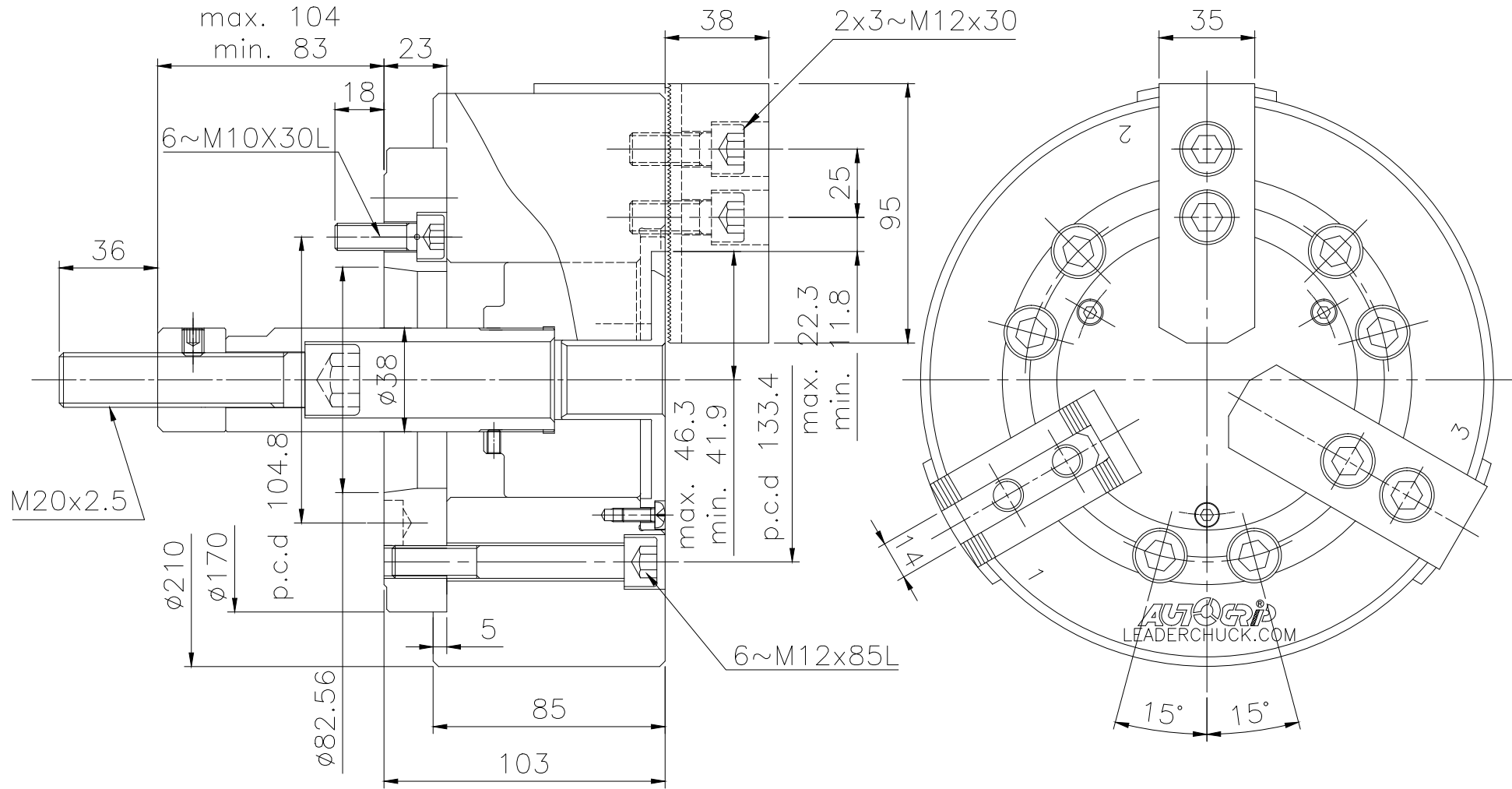

LEADER CHUCK INTERNATIONAL
+44 (0) 1827 700000
+353 (0)1 254 2555
INFORMATION@LEADERCHUCK.COM
LEADERCHUCK.COM

TITLE:
Three-jaw real power chuck

DRAWING NO.:
A4\AG-3P-08A5



	6	5	4	3	2	1
--	---	---	---	---	---	---