

8	7		6		5	4	3	2		1
	Spec.	mm	mm	Chucking Dia. mm		kgf	kgf	r.p.m.	l	kg
Model	Plunger Stroke	Jaw Stroke (Dia.)	Max.	min.	Max D.B. pull	Max clamping force	Max speed	kg m ²	Weight	Confirmed
3P-04	15	6.4	110	5	830	2300	6000	0.01	4.1	

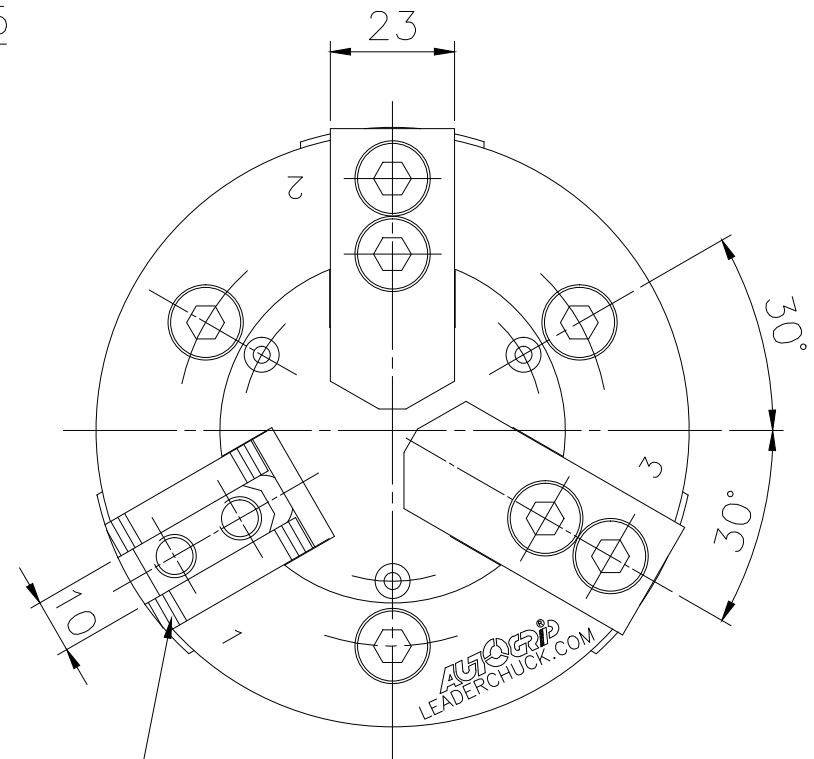
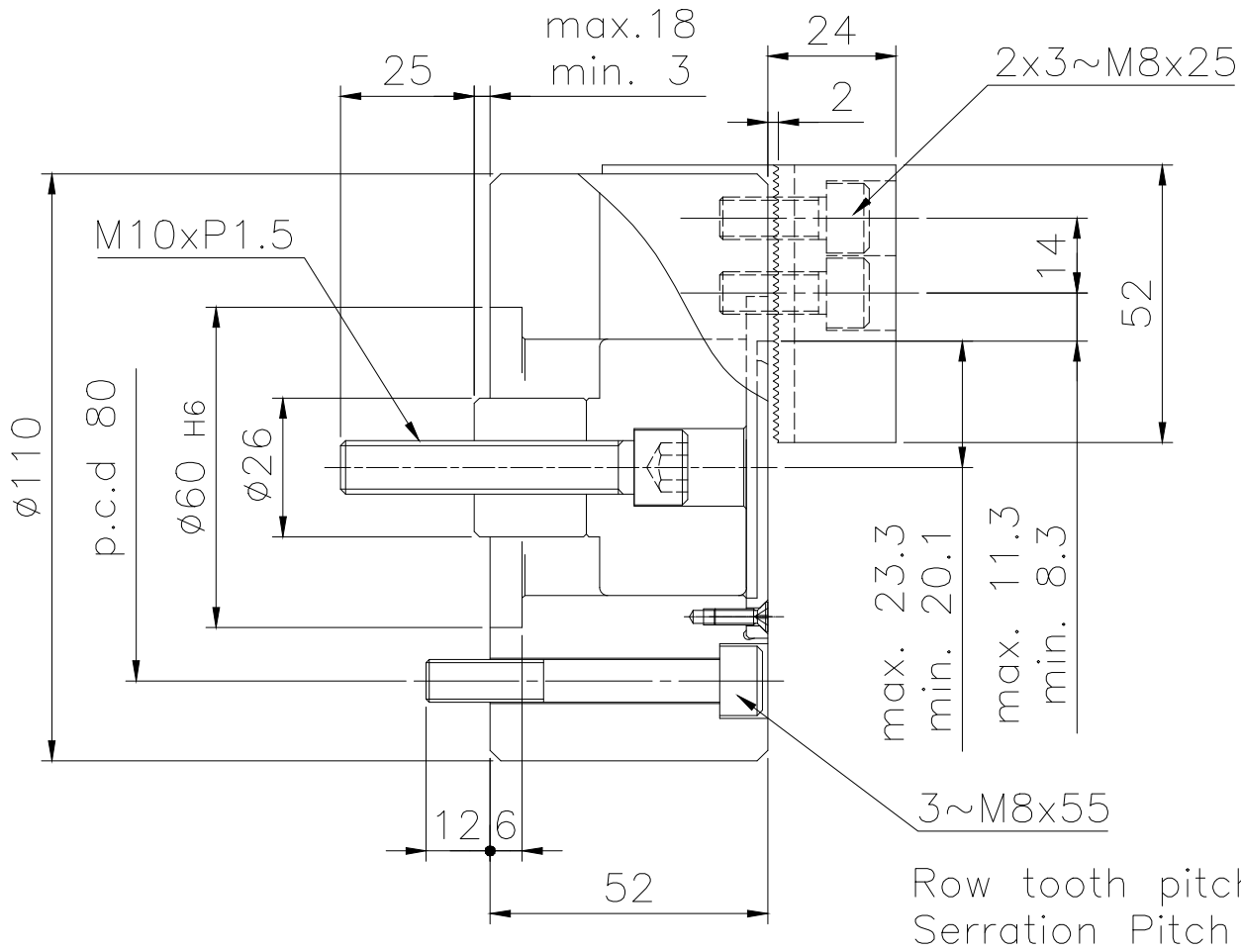

LEADER CHUCK INTERNATIONAL
+44 (0) 1827 700000
+353 (0)1 254 2555
INFORMATION@LEADERCHUCK.COM
LEADERCHUCK.COM

TITLE:
Three-jaw real
power chuck

DRAWING NO.:
A3\AG-3P-04

