

6	5	4	3	2	1				
Spec. Model	mm Plunger Stroke	mm Jaw Stroke (Dia.)	Chucking Dia. mm	kgf Max D.B. pull	kgf Max clamping force	r.p.m. Max speed	kg·m ²	kg Weight	Confirmed
3N-10	25	10.2(1.1)	254	22	2950	11000	4000	0.32	34.5

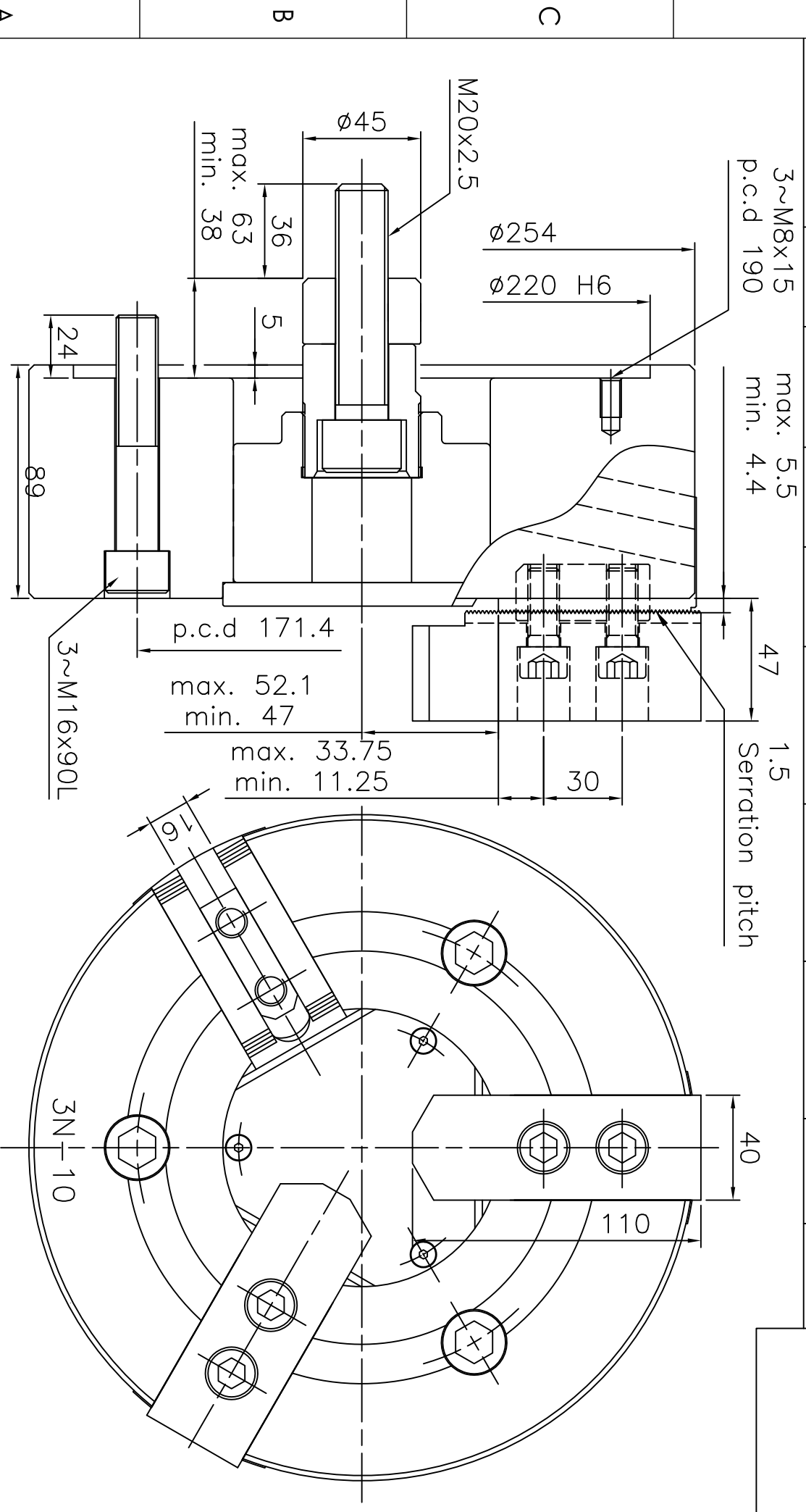

LEADER CHUCK INTERNATIONAL
 +44 (0) 1827 700000
 +553 (0)1 254 2555
 INFORMATION@LEADERCHUCK.COM
 LEADERCHUCK.COM

TITLE:
 Oblique Jaw Type Solid
 Three Jaw Chuck

DRAWING NO.:
 A4 \ AG-3N-10



6 5 4 3 2 1