

Spec.	7		6		5		4		3		2		1	
	mm	mm	mm	mm	Chuck Dia. mm		Allowable hydraulic cylinder thrust kgf	Maximum clamping force kgf	Maximum number of revolutions r.p.m.	l	kg	Confirmed		
Model	Rotating Stroke	Clamp Stroke (Dia.)	Jaw's Compensation		Max.	min.	Max D.B. pull	Max clamping force	Max speed	kg · m ²	Weight			
3J-05	12	8	2		53	25	765	612	4000	0.02	11			

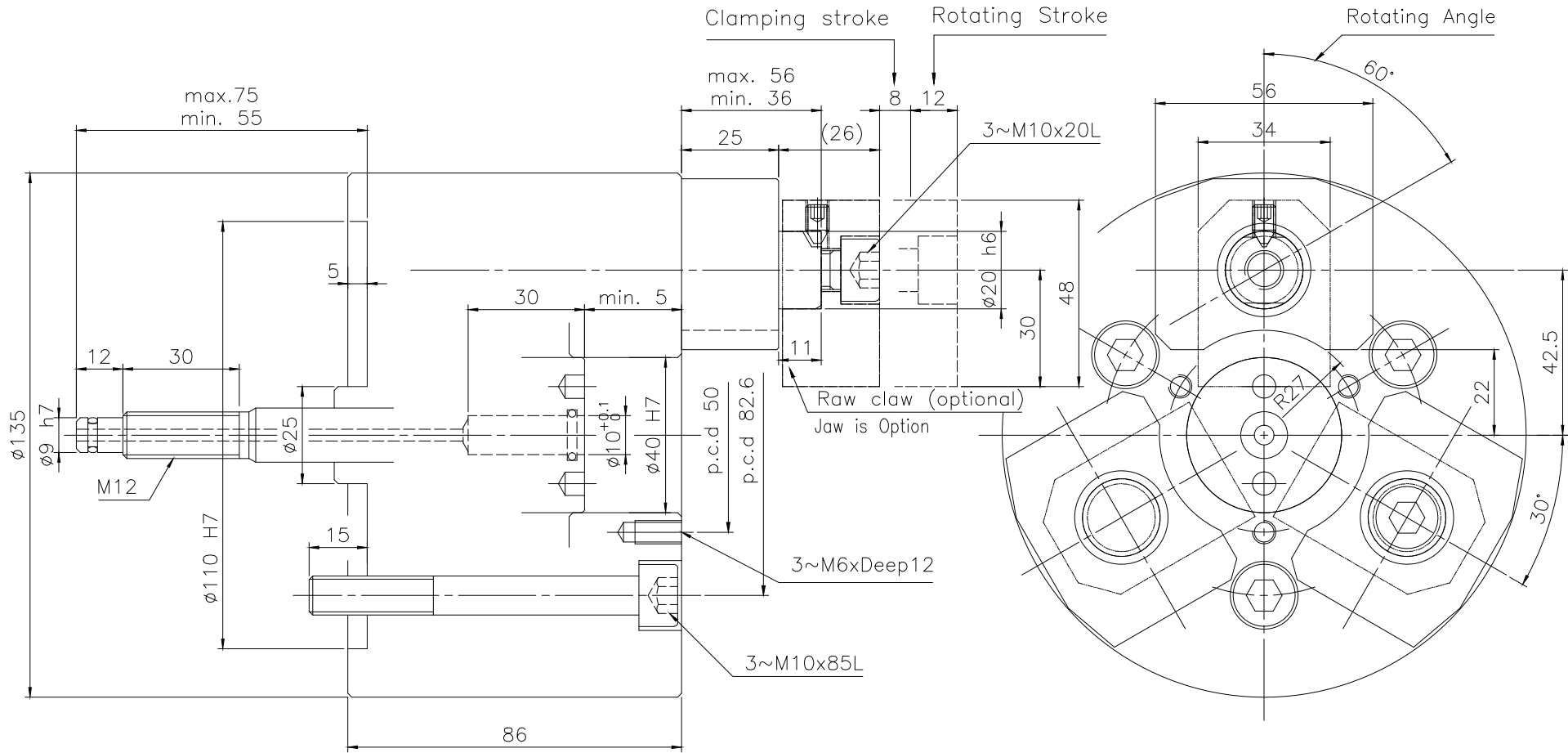

LEADER CHUCK INTERNATIONAL
+44 (0) 1827 700000
+353 (0)1 254 2555
INFORMATION@LEADERCHUCK.COM
LEADERCHUCK.COM

TITLE:
3-jaw Finger
Chuck

DRAWING NO.:

A3 \ AG-3J-05

