

| 8       | 7              |                   | 6    |                  | 5             | 4                  | 3         | 2                 |        | 1         |
|---------|----------------|-------------------|------|------------------|---------------|--------------------|-----------|-------------------|--------|-----------|
|         | Spec.          | mm                | mm   | Chucking Dia. mm |               | kgf                | kgf       | r.p.m.            | l      | kg        |
| Model   | Plunger Stroke | Jaw Stroke (Dia.) | Max. | min.             | Max D.B. pull | Max clamping force | Max speed | kg m <sup>2</sup> | Weight | Confirmed |
| 2P-12A8 | 30             | 10.5              | 304  | 22               | 2800          | 10600              | 3360      | 0.70              | 61     |           |

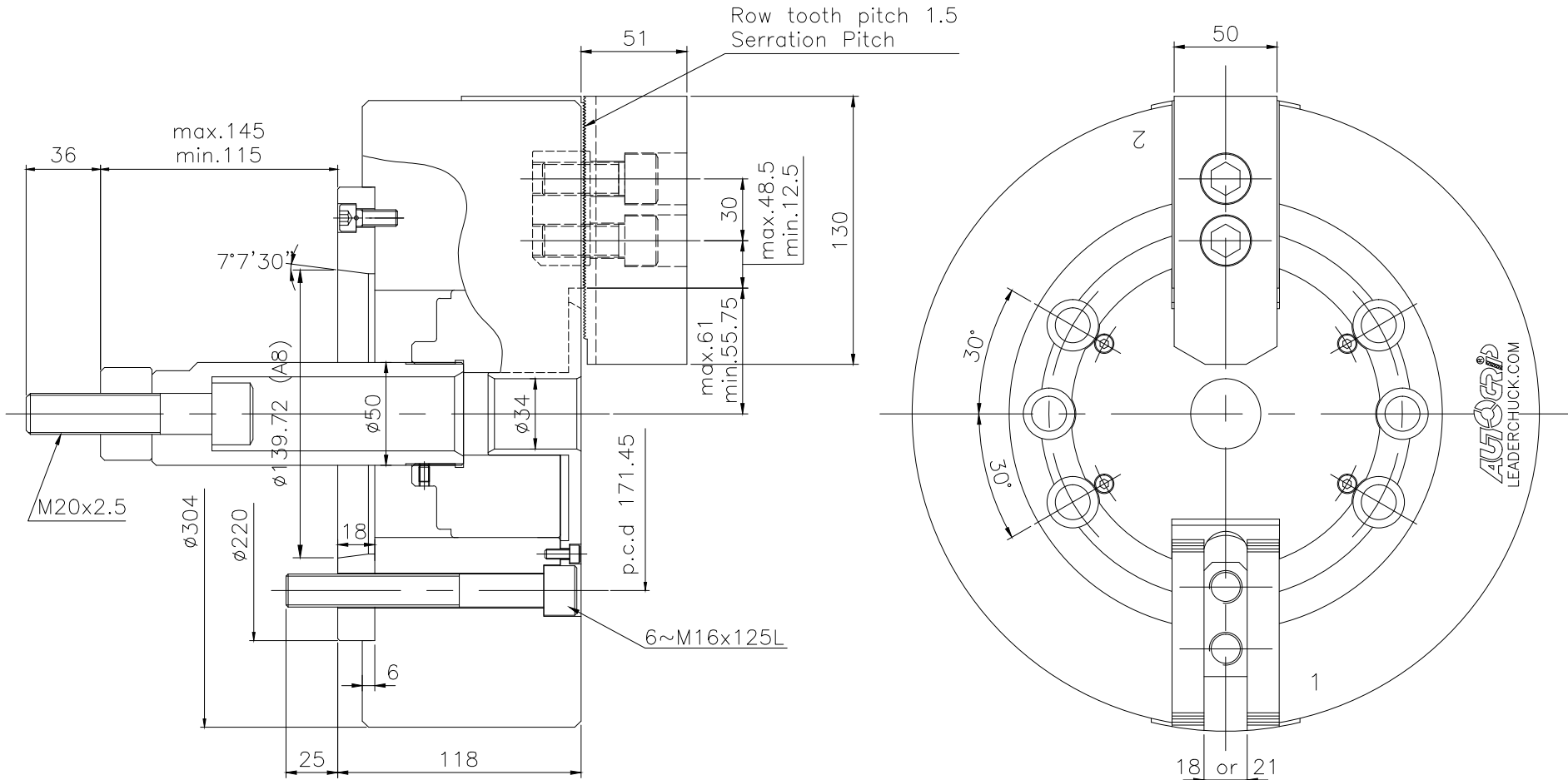

LEADER CHUCK INTERNATIONAL  
+44 (0) 1827 700000  
+353 (0)1 254 2555  
INFORMATION@LEADERCHUCK.COM  
LEADERCHUCK.COM

TITLE:  
Two-jaw real power chuck

DRAWING NO.:  
A3\AG-2P-12A8

