

8	7		6		5	4	3	2		1
	Spec.	mm	mm	Chuck Dia. mm		kgf	kgf	r.p.m.	l	kg
Model	Plunger Stroke	Jaw Stroke (Dia.)	Max.	min.	Max D.B. pull	Max clamping force	Max speed	kg m ²	Weight	Confirmed
2P-12	30	10.5	304	22	2800	10600	3360	0.70	57	

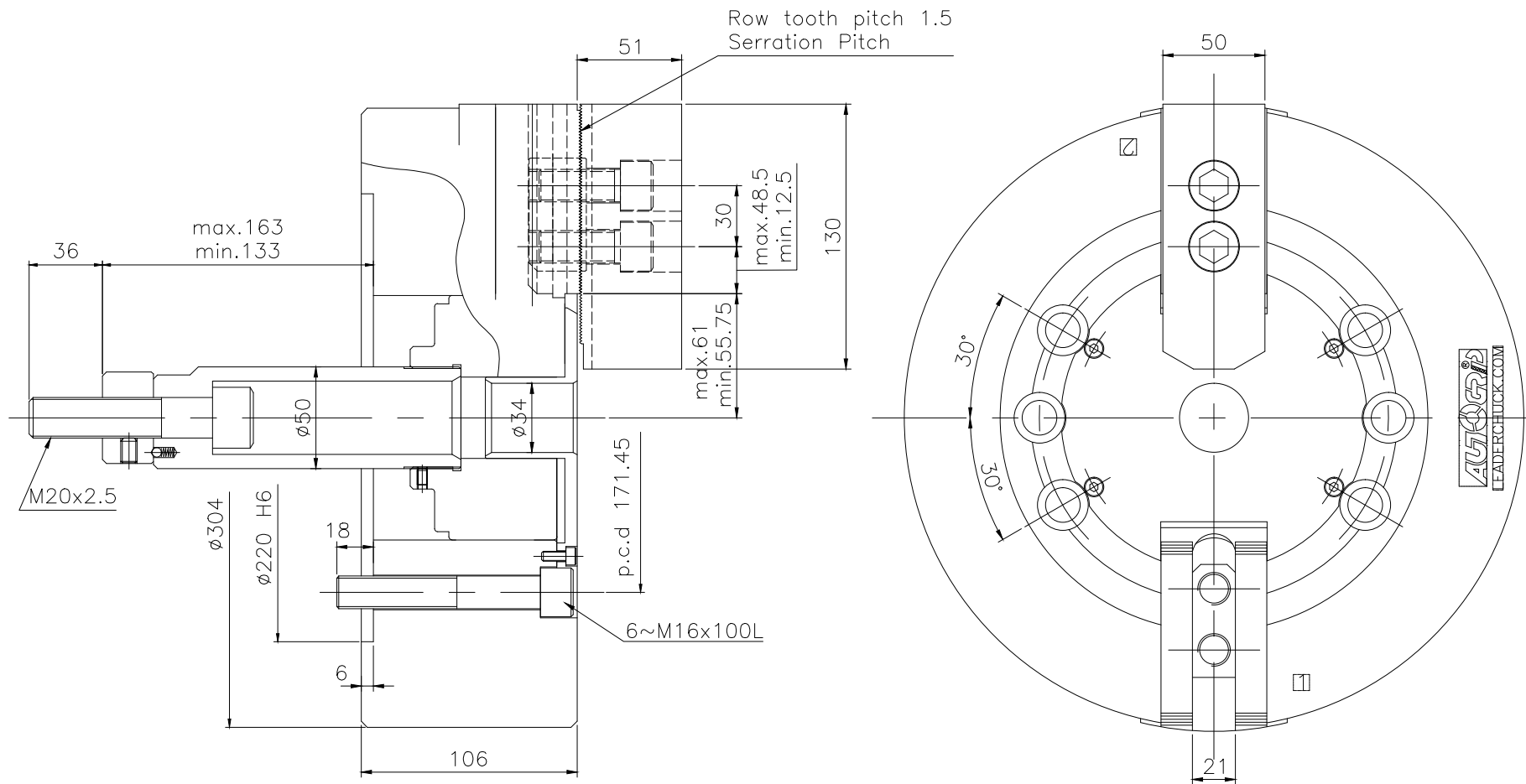

LEADER CHUCK INTERNATIONAL
+44 (0) 1827 700000
+353 (0)1 254 2555
INFORMATION@LEADERCHUCK.COM
LEADERCHUCK.COM

TITLE:
Two-jaw real power chuck

DRAWING NO.:
A3\AG-2P-12



8

7

6

5

4

3

2

1