

	6	5		4		3		2		1	
Spec.	mm	mm	Chucking Dia. mm		kgf	kgf	r.p.m.	l	kg	Confirmed	
Model	Plunger Stroke	Jaw Stroke (Dia.)	Max.	min.	Max D.B. pull	Max clamping force	Max speed	kg m ²	Weight		
2P-10A8	25	8.8	254	22	1980	7300	4000	0.29	40		

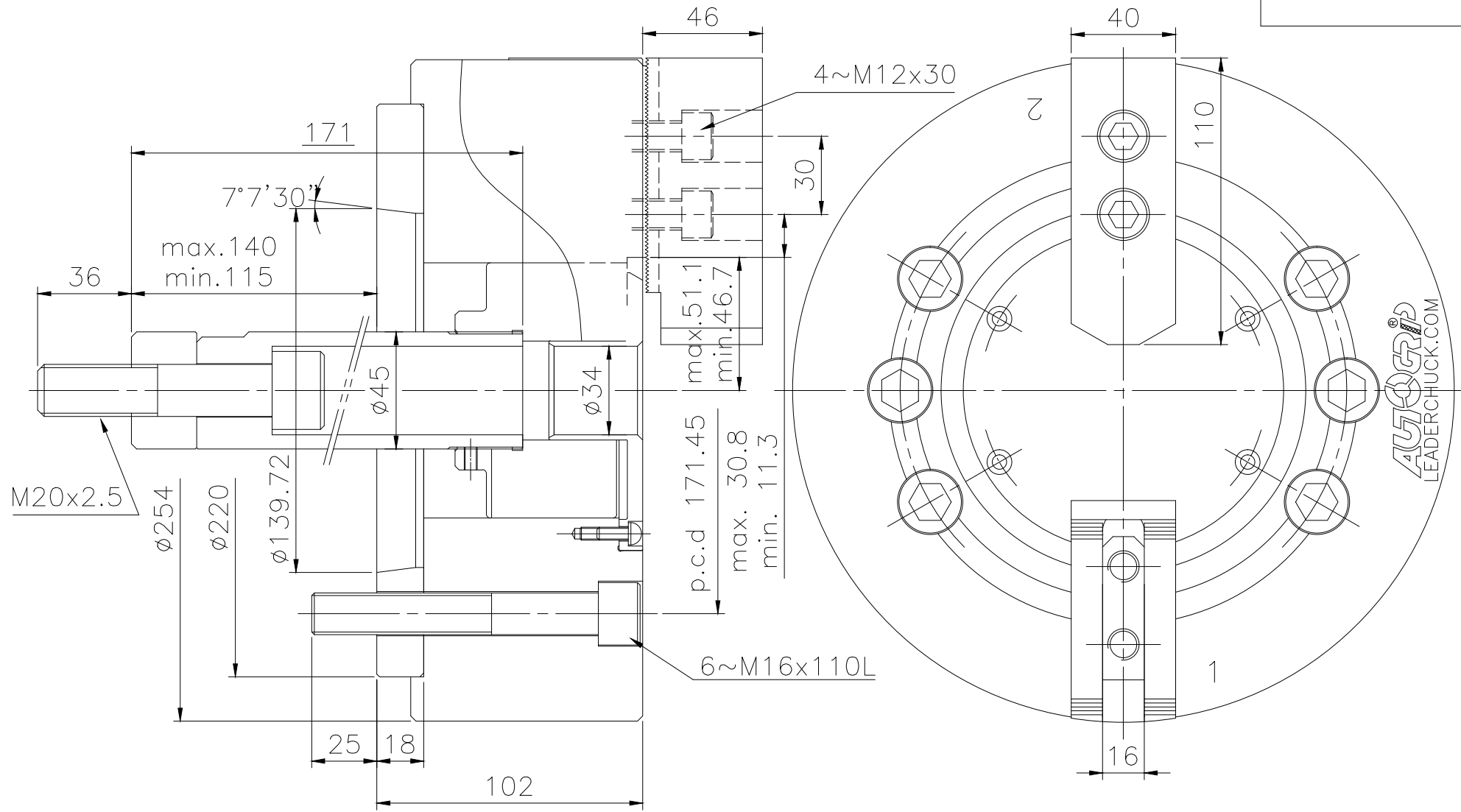

LEADER CHUCK INTERNATIONAL
+44 (0) 1827 700000
+353 (0)1 254 2555
INFORMATION@LEADERCHUCK.COM
LEADERCHUCK.COM

TITLE:

Two-jaw real power chuck

DRAWING NO.:

A4 \ AG-2P-10A8



6	5	4	3	2	1
---	---	---	---	---	---