

	6	5		4		3		2		1	Confirmed
	Spec.	mm	mm	Chucking Dia. mm		kgf	kgf	r.p.m.	l	kg	
	Model	Plunger Stroke	Jaw Stroke (Dia.)	Max.	min.	Max D.B. pull	Max clamping force	Max speed	kg m <sup>2</sup>	Weight	
D	2P-08A5	21	8.8	210	17	1680	5100	4750	0.13	26	D

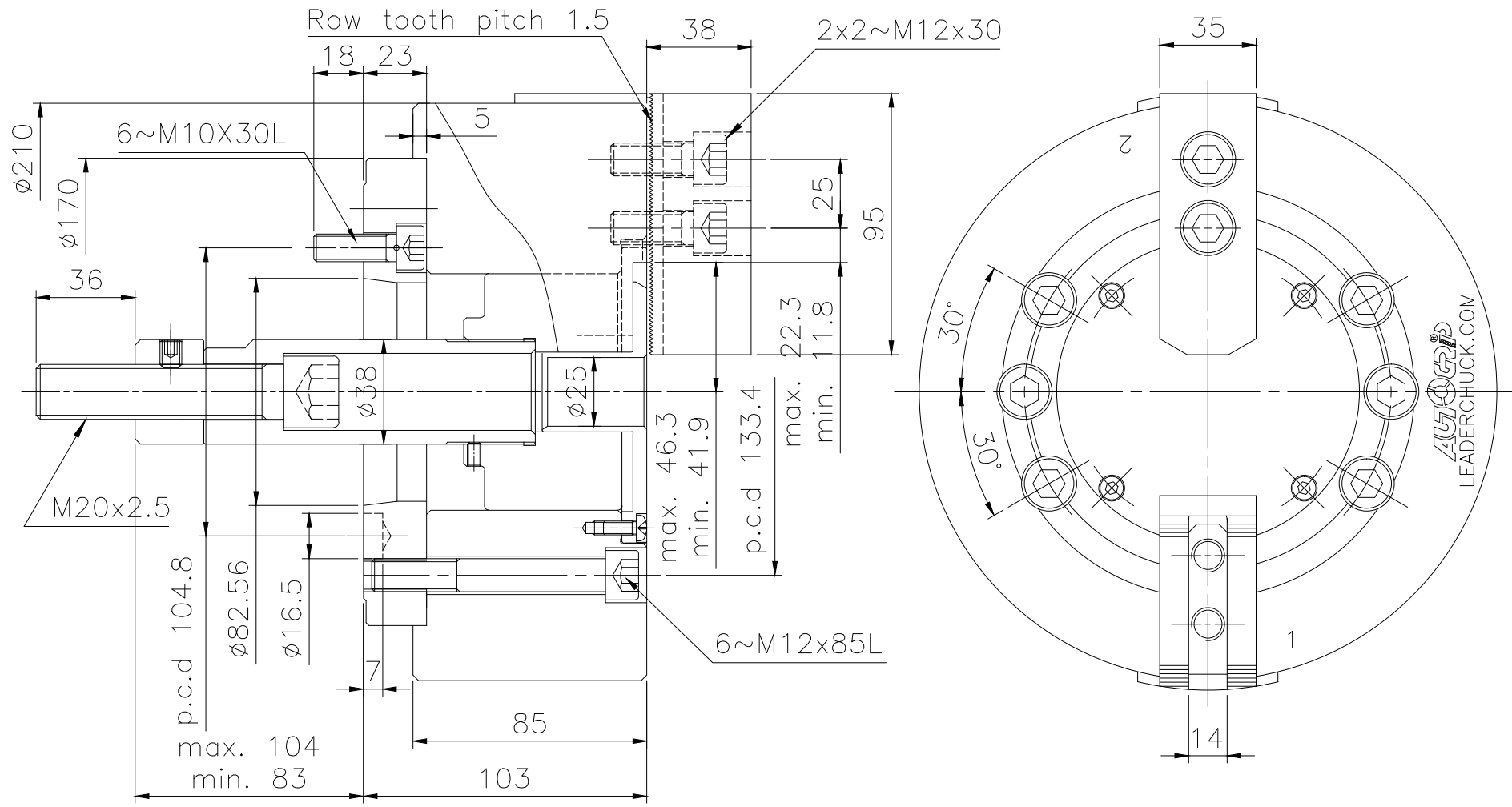

LEADER CHUCK INTERNATIONAL  
+44 (0) 1827 700000  
+353 (0)1 254 2555  
INFORMATION@LEADERCHUCK.COM  
LEADERCHUCK.COM

TITLE:  
Two-jaw real power chuck

DRAWING NO.:  
A4\AG-2P-08A5



	6	5		4		3		2		1
--	---	---	--	---	--	---	--	---	--	---