

6	5		4		3		2		1	
Spec.	mm	mm	Chucking Dia. mm		kgf	kgf	r.p.m.	l	kg	Confirmed
Model	Plunger Stroke	Jaw Stroke (Dia.)	Max.	min.	Max D.B. pull	Max clamping force	Max speed	kg m <sup>2</sup>	Weight	
2P-208	21	8.8	210	17	1680	5100	4750	0.13	22	

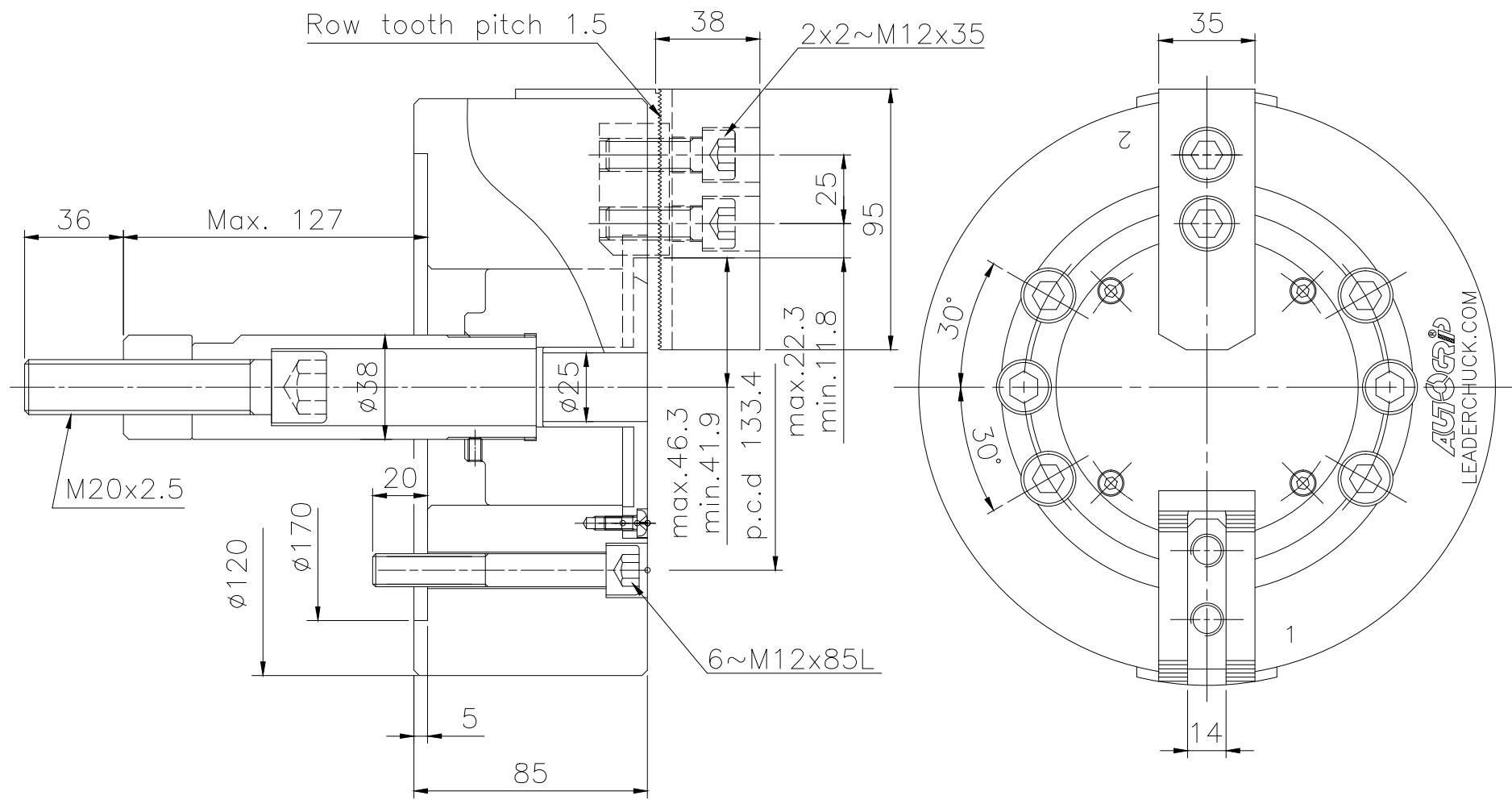

LEADER CHUCK INTERNATIONAL  
+44 (0) 1827 700000  
+353 (0)1 254 2555  
INFORMATION@LEADERCHUCK.COM  
LEADERCHUCK.COM

TITLE:  
Two-jaw real power chuck

DRAWING NO.:  
A4\AG-2P-08



6	5		4		3		2		1	
---	---	--	---	--	---	--	---	--	---	--