

	6		5		4		3		2		1
D	Spec.	mm	mm	Chucking Dia. mm		kgf	kgf	r.p.m.	l	kg	Confirmed
	Model	Plunger Stroke	Jaw Stroke (Dia.)	Max.	min.	Max D.B. pull	Max clamping force	Max speed	kg m ²	Weight	
	2P-06	20	8.5	165	14	1220	3570	5250	0.04	12	

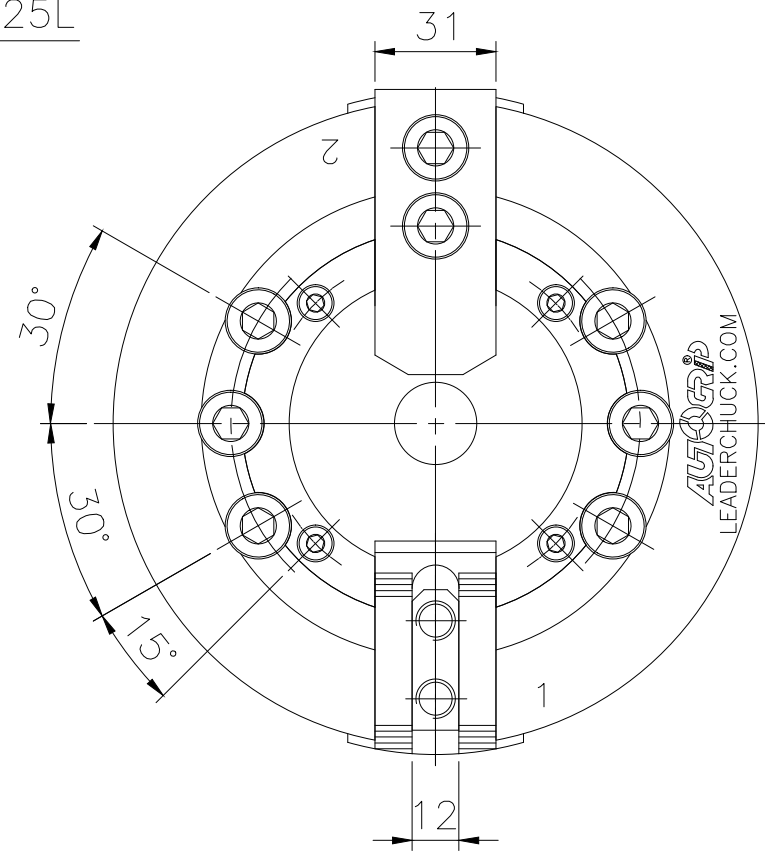
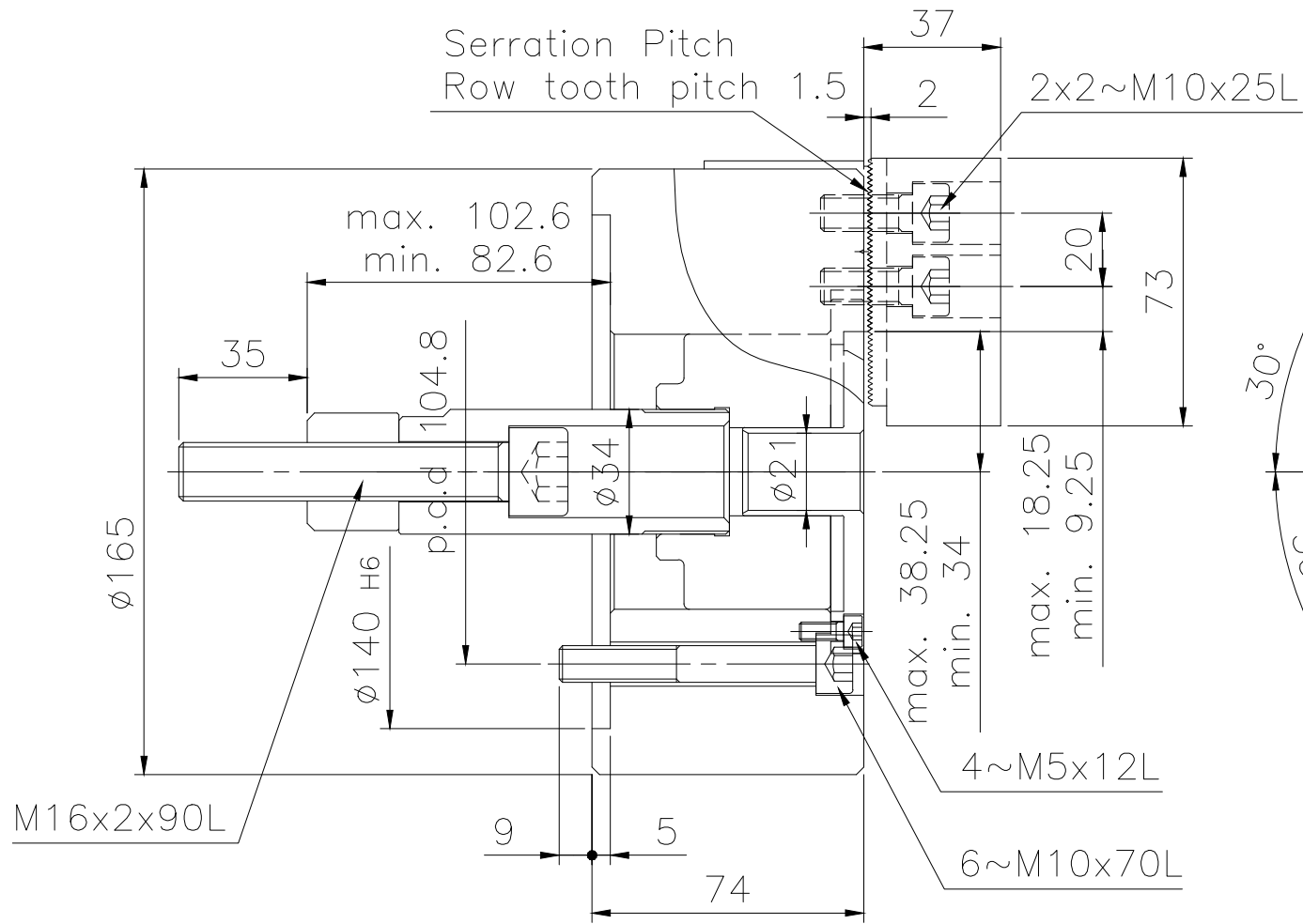

LEADER CHUCK INTERNATIONAL
+44 (0) 1827 700000
+353 (0)1 254 2555
INFORMATION@LEADERCHUCK.COM
LEADERCHUCK.COM

TITLE:
Two-jaw real power chuck

DRAWING NO.:
A4 \ AG-2P-06



	6		5		4		3		2		1
--	---	--	---	--	---	--	---	--	---	--	---